



POWER ARM TECHNOLOGY

Quality, innovation and performance

World leader in hedge-cutting and green maintenance technology



CONTENTS

Proven Heritage.....	3	POWER ARM RANGES	28-29	FLAILHEADS & ROTORS	68-69
What's New for Power Arms	4-5	Swingtrim	30-31	The Range of McConnel Flails	70-71
ADVANCED CONTROLS	6-9	30-series	32-33	The Range of McConnel Flailheads	72-73
MOUNTING & STABILITY	10-11	35-series	34-35	Flailhead Options and Accessories	74-75
ARMSETS	12-15	45-series	36-37	POWER ARM ATTACHMENTS	76
HYDRAULICS	16-17	55-series	38-41	Ditch Cleaner	77
Floatation Systems	18-19	60-series	42-43	Cutterbars	78-79
Hydraulics Features & Upgrades	20-21	67-series	44-45	Multisaws	80
POWER ARM SAFETY EQUIPMENT & PRODUCTIVITY	22-27	72-series	46-47	Rotary Heads	81
		75-series	48-51	Why McConnel?.....	82-83
		77-series	52-53	Contacts.....	84
		85-series	54-61		
		Versi-series	62-65		
		Barrier Mower	66-67		



PROVEN HERITAGE

The world's leading manufacturer of Power Arm technology, McConnell has blazed a trail for innovation, quality and performance since creating the world's first tractor-mounted hedge-cutter back in 1948.

McConnell continues to set new benchmarks for Power Arm design – winning worldwide recognition with more than 40 major national and international engineering awards.

Driven by innovation, McConnell has pioneered a series of world firsts in the industry including:

- The world's first tractor mounted hedge-cutter
- The world's first dual-rotor flailhead
- The world's most advanced Power Arm control system
- The world's first hands-free EDS cruise control mowing system

With a proud heritage and eight decades of specialist experience, no other company can match McConnell's expertise in Power Arm design, its comprehensive range of products, or the thousands of customisation options it offers those wishing to create machines to a precise personal specification.

It remains the most trusted Power Arm brand in the world with an unrivalled network of dealers and international distributors, and booming export sales to more than 40 different countries from Norway to New Zealand, Canada to China.



WHAT'S NEW FOR POWER ARMS

McConnel works constantly to improve its Power Arms, attachments and accessories - enhancing and expanding its product range with innovative designs, purpose-built components, and state-of-the-art engineering technology. Here's a look at some of the most important new products we're introducing:



RUGGED AND HEAVY DUTY - 75 SERIES

McConnel have launched a 75-series specifically designed for full time contractors. Powered by high performance 70hp hydraulics and featuring a radical new oil tank and cooling system, the 75-series provides peak performance in all conditions.

THE NEW 9.0M REACH PA9085TT POWER ARM

The biggest Power Arm ever developed by McConnel, the new PA9085TT has been created for embankment and verge mowing. It offers an unrivalled 9.0m reach, 85hp hydraulics, and a twin-telescopic armset which lets operators tackle the parts other reach arms cannot.



TOUGHER AND MORE STABLE – TUFFCUT FLAILHEAD'S IDEAL FOR PROFESSIONALS

McConnel's new Tuffcut flailhead is setting new standards for strength and durability – featuring an innovative new lug design that's 65% stronger and a larger diameter rotor that's up to 75% stiffer. Available in 1.2m and 1.6m working widths it's an ideal choice for professional contractors.



NEW HIGHER SPECIFICATION 55 SERIES - PA5555-60

A new, higher specification model to the 55-Series range has been launched. Ideal for farmers looking for a little extra reach (5.5m) and 60hp hydraulic power. The new model also comes with integrated oil cooler and LED road lighting as standard.



EASY ADJUSTMENTS WITH THE NEW HYDRAULIC FRONT HOOD

Ensures quick and easy adjustment of the front hood to improve the ingress of material when cutting thick vegetation and tailor the machine's performance to a full range of hedge cutting and verge mowing duties.



F14 FLAIL – THE BEST JUST GOT BETTER!

Packed with innovative design refinements (including a weight-saving patented cavity shaft), the new F14 flail delivers an exceptional cutting performance and is equally adept at cutting grass and mature hedges.

AN EXTRA AXIS OF STABILITY WITH THE NEW 4-POINT HITCH MOUNTING SYSTEM

The new system uses traditional three-point linkage mounting but also connects to the tractor's pick-up hitch for an extra axis of stability. The mounting system is easy to fit; is compatible with any mounted tractor with a pick-up hitch; and does not require any additional tractor brackets.



For more information please visit www.mcconnel.com

65 SERIES POWER INCREASE

McConnel's popular 65 Series Power Arm range has received hydraulic system upgrade for greater output and performance. All 65-Series now come with 70hp hydraulic system as standard, a step up for the original 65hp.



ENHANCED CUTTING RANGE FOR POWER ARMS

A new range of robust Multisaws is now available from McConnel. Made from high-tensile steel and armed with the bite of super-strength tungsten carbide teeth. McConnel Multisaws deliver the perfect combination of a powerful cutting action and long-lasting durability.



MCCONNEL'S VERSATILE PA4030 VERSI

One of the most versatile Power Arms ever developed by McConnel the 4.0m reach PA4030 VERSI features front and rear mounting options, a 180-degree slew, and a full-width hydraulic side shift that enables operators to switch to and from left and right hand cutting.

FASTER, EASIER AND SMARTER WITH THE NEW QUICK ATTACHMENT BRACKETS

McConnel's quick-attachment brackets enable operators to interchange Power Arm attachments in minutes, saving time and hassle and improving productivity.

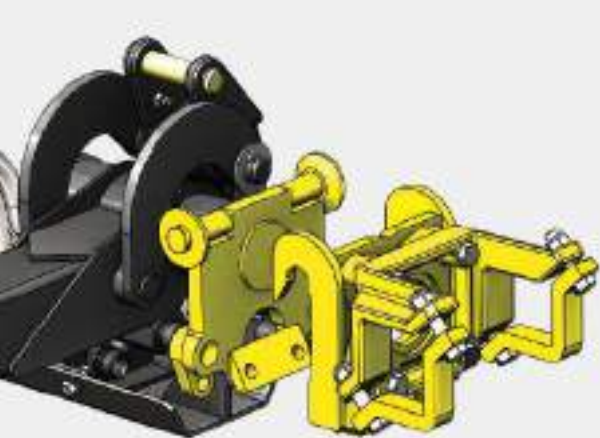

ADVANCE NEW REVOLUTION CONTROL SYSTEM IS NOW AVAILABLE

McConnel has further refined the flagship Revolution control system with the introduction of a new digital display unit, soft touch armrest and mini joystick option. Revolution provides full proportional control of up to 8 different functions and full one-handed control.



ADVANCED FLOAT

This automatic lift floatation system reduces operator input and enables hands-free verge mowing.

PA6585 TELE-VFR

McConnel's most advanced Power Arm series gets a new model featuring the market-leading Telescopic VFR armset. The new 6.5m reach edition complements the 7.2m and 8.0m models and is ideal for professional contractors seeking the best in comfort, precision and flexibility.

REVOLUTION

REVOLUTION features eight proportional controls and two bang-bang functions; market-leading joystick technology; and advanced software developed in-house by McConnell.

For further details go to page 8



EVOLUTION

A new seven function controller (six proportional) which offers the proven REVOLUTION joystick; advanced key-mapping customisation options; and a new-style comfort armrest.

For further details go to page 9



MOTION

A seven function (six proportional) controller with a compact short stick for light, intuitive fingertip control, and an optional new armrest.

For further details go to page 9



“

I was used to all-on, all-off controls, so the large number of proportional controls you get with REVOLUTION are a big improvement over other systems and give a lot more precision."

Mathew Williams,
Pembrokeshire contractor



ADVANCED CONTROLS

McConel offers the most advanced Power Arm control systems anywhere in the world, delivering the best in fingertip precision, multi-functional proportional control, and simple yet sophisticated software created exclusively for McConel Power Arms.

A choice of six different control systems is available from tried and trusted traditional cable controls, which offer simplicity and value, to the state-of-the-art REVOLUTION system which comes with a compact 4.25" high visibility touch screen display, a state-of-the-art joystick with advanced keymapping and eight-function proportional controls.

No other company comes close to matching the features, precision, or functionality of McConel's control systems, and no other manufacturer can deliver the same market-leading standards of precision and manoeuvrability.



NEXT GENERATION CONTROL TECHNOLOGY

REVOLUTION

Simple to use, yet highly sophisticated, REVOLUTION blows away outdated and generic control systems - delivering outstanding one-handed control and the best feature set in the industry.

REVOLUTION is a state-of-the-art multi-function reach arm control system that enables users to tackle a huge variety of work tasks; offers huge strides in productivity, safety and reliability; and enables precise fingertip control for outstanding manoeuvrability. McConnel's REVOLUTION is the first control package ever developed which gives operators full proportional control of up to eight different functions, as well as two further bang-bang functions. It also comes with McConnel's acclaimed Easy Drive System, boosting safety and increasing verge-mowing speeds by up to 4.5 times the norm.

REVOLUTION CONTROL SYSTEM FEATURES INCLUDE:

- **Full colour display** – The compact 4.25 inch high visibility display is the best on the market with a high quality touch screen and robust build quality. The screen can be mounted round the cab and provides at-a-glance information on active functions, power output, job hours, warning alarms and servicing alerts.
- **Ergonomic joysticks** – Developed in-house exclusively for Power Arms, both the standard and mini joystick options allow full proportional control of up to eight different functions from the joystick and full one-handed control of even the most complex operations.
- **Fully customisable controls** – REVOLUTION makes it easy for customers to customise the joystick buttons to a variety of different functions, allowing you to create a configuration for your personal preferences or for a specific task. You can even switch between configurations at the touch of a button – giving you full control.



REVOLUTION MINI

Our REVOLUTION control is now available with a Mini Joystick.





EVOLUTION

Created for customers who demand outstanding precision and functionality, EVOLUTION offers seven-function controls; advanced joystick technology; and a robust design capable of withstanding the demands of busy professional contractors. Six proportional functions are available for light fingertip control, while the joystick enables operators to customise the controls to suit their personal preferences or the job at hand.

ADVANCED FLOAT CRUISE CONTROL

Created as a value-for-money cruise control system, EVOLUTION's Advanced Float system automatically adjusts the height of the flailhead to suit the contours of the ground when used in conjunction with an angle float kit, leaving the operator to regulate only the reach.

More effective and flexible than a standard lift float kit, the system thrives on embankments and verges and enhances working speeds, comfort and visibility.



MOTION

McConnel's Motion control system is an easy-to-master seven-function (six proportional) controller which offers light and precise fingertip control of complex manoeuvres and operations.

Featuring an ergonomic control pod, purpose-built software, and a precise 'short-stick', the system has been created to be rugged, responsive and reliable.

Motion is available with a reinforced polyurethane foam armrest which is not only hard-wearing and durable, but also offers greater comfort.

MOTION MINI

The controller of choice for compact Power Arms, featuring three proportional functions and a responsive mini stick for enhanced precision.



CABLE

Controls for those seeking a simple, no-frills progressive controller that is easy to learn and master.





3-POINT LINKAGE

Stable mounting that is compatible with a comprehensive range of tractor makes and models.

Benefits include:

- Easy to fit and universally compatible
- Integrated stabiliser frame as standard
- Triangulated stabiliser geometry for added strength and stability
- Unique floating nose cone distributes forces equally across lower link arms and top link
- Integrated transport dampening to protect the Power Arm and tractor
- Interchangeable stabiliser nose to accommodate a range of tractors



4-POINT HITCH MOUNTING

Uses traditional three-point linkage mounting but also connects to the tractor's pick-up hitch for extra stability.

Benefits include:

- Easy to fit and universally compatible
- Integrated stabiliser frame as standard
- Triangulated stabiliser geometry for added strength and stability
- Unique floating nose cone distributes forces equally across lower link arms and top link
- Integrated transport dampening to protect the Power Arm and tractor
- Interchangeable stabiliser nose to accommodate a range of tractors
- Additional fixing point to pick-up hitch provides an extra axis of stability
- Improved rigidity



3-POINT TO 5-POINT AXLE MOUNTING

A sub-frame mounting kit that converts 3-point mounting Power Arms to a 5-point axle mounting configuration.

Benefits include:

- Flexibility to switch between 3-point linkage and 5-point axle mounting for different tractors
- Convert any machine from the 60-series upwards to 5-point axle mounting
- Locks Power Arm directly to tractor axle for total rigidity and stability
- Distributes Power Arm weight evenly across five points (rear axle and 3-pt linkage)
- Reduces stress and strains on the tractor linkage
- Improves safety and stability when working at full reach extension
- Enhanced rigidity prevents wear and tear on both the Power Arm and the tractor
- Heavy-duty rubber shock absorber for safe and stable transit
- Can be safely and easily fitted or removed in less than five minutes



5-POINT AXLE MOUNTING

McConnel's most rigid mounting system, five-point axle mounting offers rock-solid stability that's perfect for larger Power Arms and professional users.

Benefits include:

- Locks Power Arm directly to tractor axle for total rigidity and stability
- Distributes Power Arm weight across five points (rear axle and 3-pt linkage)
- Reduces stress and strains on the tractor linkage
- Enables the tractor to safely carry heavier and longer reach machines
- Improves safety and stability when working at full reach extension
- Enhanced rigidity prevents wear and tear on both the Power Arm and the tractor
- Heavy-duty rubber shock absorber for safe and stable transit
- Can be safely and easily fitted or removed in less than five minutes
- No need to remove the tractor lower link arms
- Axle brackets available for all makes and models of tractor

MOUNTING & STABILITY

McConnel offers the most stable and sturdy mounting systems in the business, ensuring the Power Arm can be attached to the tractor safely, quickly and securely in minutes.

5-point axle brackets are ideal for McConnel's large flagship Power Arms such as the 70 and 85-series. They are exceptionally robust and deliver outstanding stability by fixing the machine rigidly to the tractor.

They reduce the strain on both the Power Arm and the tractor and deliver a stable cutting platform for a fine finish. A key advantage over rival mounting systems is the ability to fit the Power Arm without having to remove the tractor lift arms.

CUSTOM MOUNTING SYSTEMS

In addition to the standard mounting systems listed, McConnel also offer a variety of specialist mounting solutions for a wide range of Power Arms and power units, such as: front mounts for tractors, DIN plate mounting for skid steers and custom builds for wheeled loaders. For further details please contact the McConnel Sales team.



ARMSETS

McConel offers the most advanced and comprehensive choice of armsets in the industry, with a series of next-generation models and a reach range from 3.2m to 9.0m.

Precision-engineered in the UK and made from super-strength Domex steel, the arms are designed to offer a winning combination of strength and reach and are created to withstand the busy workloads of professional contractors.

FOCUS ON THE ADVANCED TELE-VFR

TELESCOPIC-VARIABLE FORWARD REACH

Modern tractor cabs increasingly place the operator ahead of the rear axle. Great for comfort, this position does nothing for visibility of the flailhead when hedge-cutting or mowing verges. Telescopic-Variable Forward Reach (TELE-VFR) is designed to aid visibility from all types of cab and makes cutting around obstacles much easier.

Constructed from super-strength Domex steel for durability and lightness, the unique range of movement delivered by TELE-VFR delivers a 400% larger working zone for operators, boosting both precision and productivity.



TELE-VFR enables operators to cut directly behind the cab when working in very narrow lanes where space is at a premium and there is no room to extend the arm. This creates opportunities for work in challenging environments where a conventional reach arm machine would struggle.



THE BENEFITS OF VARIABLE FORWARD REACH TECHNOLOGY

SAFETY AND VISIBILITY

Conventional arms extend behind the cab resulting in operators having to make a series of visual adjustments from front to rear as the operator checks the road ahead, then breaks off to check the performance of the flailhead.

TELE-VFR takes full advantage of the 120-degree focal range of the human eye, allowing operators to flick simultaneously back and forth from the road to the flailhead's position alongside the cab without compromising safety. The improvements in visibility help increase working speeds, enhance safety and greatly increase comfort for the operator.

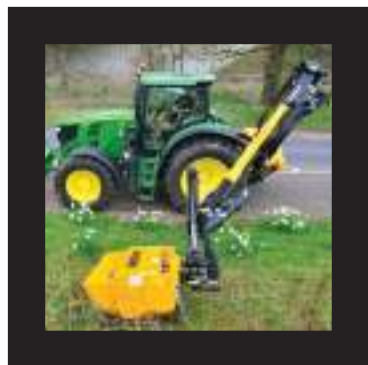

GREATER PRODUCTIVITY

Conventional reach arms are not designed for cutting around obstacles such as road signs and trees and therefore struggle to make a tidy cut without being forced into a series of time-consuming and potentially hazardous manoeuvres.

By enabling an extended forward reach of up to 2.39m, TELE-VFR offers an increase of over 400% in the size of the cutting area, boosting efficiency and productivity and enabling the arm to cut behind obstacles.

CONVENTIONAL ARM CONFIGURATION



Arm positioned behind the cab

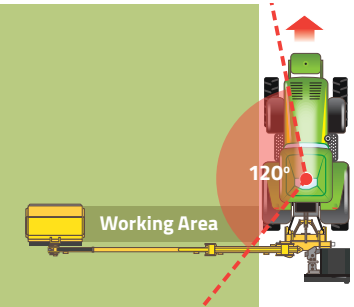

Focus on cutting attachment

TELE-VFR ARM CONFIGURATION



Arm can be positioned alongside the cab

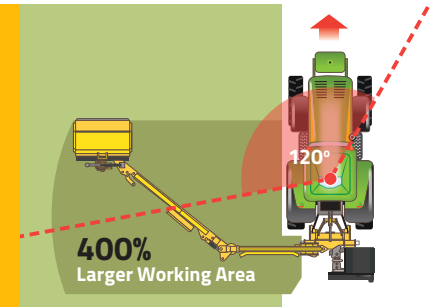

400%
Larger Working Area

Focus on cutting attachment and road ahead

THE RANGE OF MCCONNEL ARMSETS

McConnel's armset technology is recognised around the world as the most innovative and advanced in the industry.

Five distinct configurations are available offering operators the best in comfort and reliability, precision and productivity.

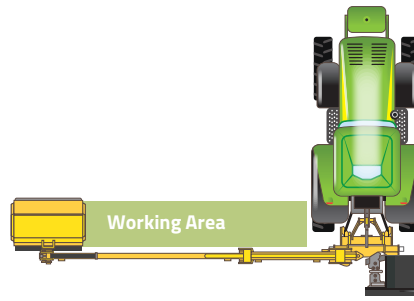

STANDARD ARMSET

A proven armset with a long and successful track record for durability and performance, McConnel's standard arms are robust and reliable.

Benefits include:

- Simple design with hoses neatly routed and protected behind the arm
- Award-winning arm geometry
- Tapered C-section arms ensure outstanding strength at all reaches

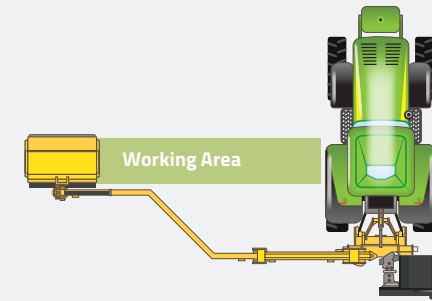

MID-CUT ARMSET

A fixed forward reach armset that positions the cutting attachment alongside the cab.

Benefits include:

- Delivers greater visibility
- Full reach at full forward extension
- Improves safety and precision
- Enhances comfort



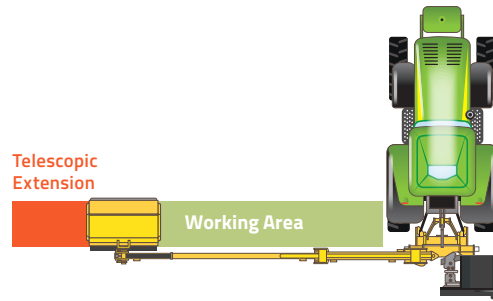

TELESCOPIC ARMSET

Featuring a precise telescopic arm extension which delivers extra reach on demand.

Benefits include:

- Greater cutting flexibility
- Delivers added reach within a compact armset
- Intuitive and responsive arm extension
- Robust build quality with heavy-duty wear pads
- Aids manoeuvrability in confined environments

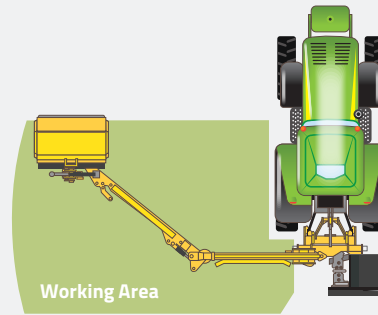

VARIABLE FORWARD REACH

McConnel's world-renowned VFR armset delivers the very best in flexibility and precision, enabling the operator to position the cutting attachment at any point along the cutting range that runs from alongside the cab to behind the tractor wheel.

Benefits include:

- Outstanding cutting flexibility
- Improves comfort and visibility
- Ideal for working around obstacles
- Positions the cutting head behind the machine
- Boosts safety by enabling operators to concentrate on road ahead
- Allows operators to set the arm position to the task at hand

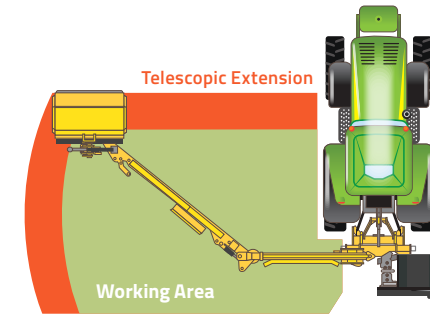

TELESCOPIC-VARIABLE FORWARD REACH

McConnel's elite armset for professional contractors features the combined benefits of a telescopic-arm extension with the flexibility and precision of Variable Forward Reach.

Benefits include:

- Unrivalled comfort, visibility and precision
- Increases the cutting range by up to 400%
- Delivers added reach within a compact armset
- Aids manoeuvrability in confined environments
- Ideal for working around obstacles
- Positions the cutting head behind the machine
- Boosts safety by enabling operators to concentrate on road ahead
- Allows operators to set the arm position to the task at hand



HYDRAULICS



McConnel's high-performance hydraulic systems are unrivalled in the industry – ensuring operators receive the most powerful, precise and responsive performance.

The centrepiece of McConnel's best-in-class hydraulic systems is the hydraulic valve block which acts like a 'beating heart' moving oil around the arm for peak performance.

To ensure the best in power delivery and responsiveness, McConnel has invested hundreds of thousands of pounds in the latest Mazak milling technology – enabling the company to create its own exclusive valve blocks for McConnel machines, to the most demanding specification in the industry.

PUMPS

McConnel Power Arms are fitted with the latest high-performance pumps sourced from suppliers with a proven track record for quality and reliability. Hydraulic systems range from 30hp for compact Power Arms right up to 120hp for powerful customer-spec machines.

- All pumps are built to comply with ISO9001 standards of quality and are tested extensively on site

HIGH-CAPACITY OIL COOLERS

Helps machines stay cool for peak performance, while enhancing the lifespan of the oil.

- An extensive development programme has delivered low noise levels and high levels of resistance to leakage, vibration, corrosion and burst pressure

OIL FILTERS

McConnel oil filters are so effective they can filter debris that's one seventh the width of a human hair.

- 99% of contaminants removed
- Protects machine from pressure surges
- Prolongs machine life

HOSES

McConnel uses premium quality hoses, which are widely recognised as the best in the industry.



PROVEN QUALITY AND RELIABILITY

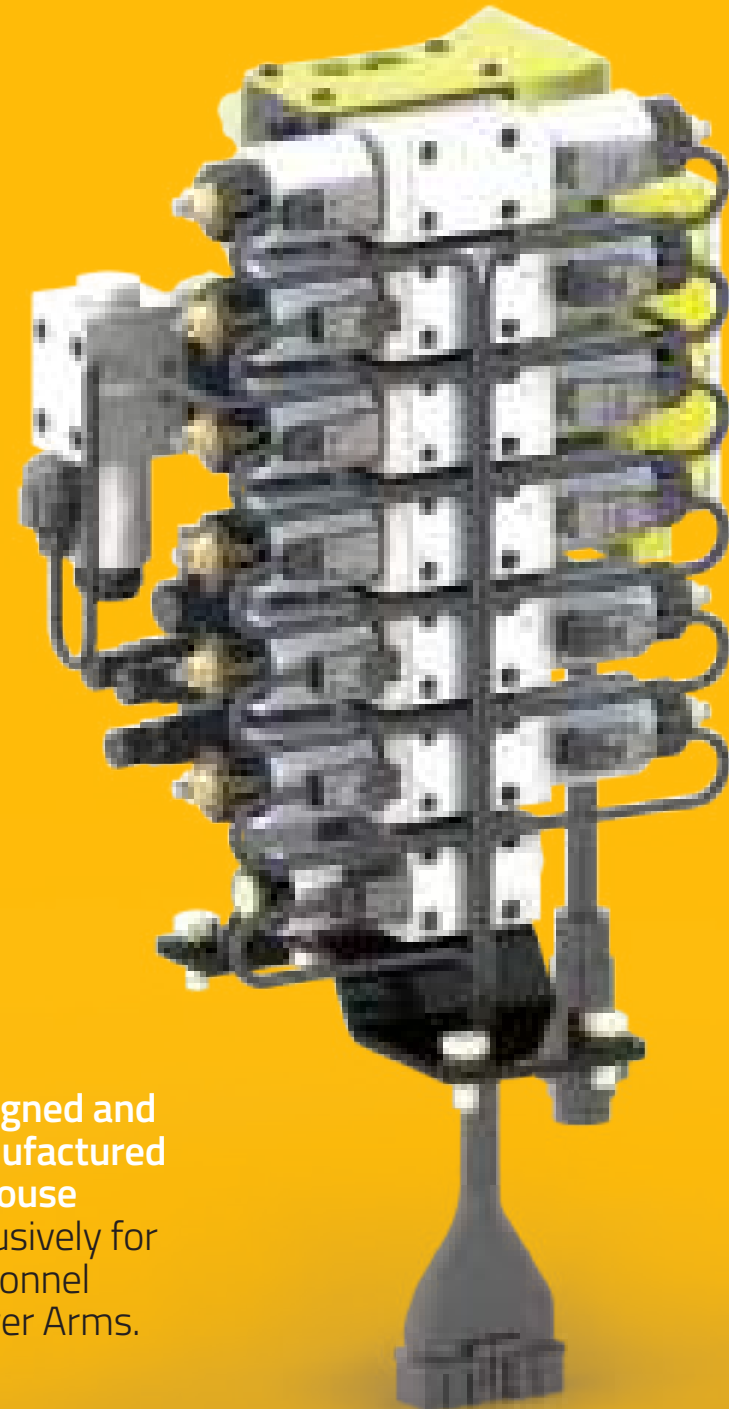

Designed and
manufactured
in-house
exclusively for
McConel
Power Arms.

MCCONNEL FLOATATION SYSTEMS

McConnel enables you to work harder, faster and smarter thanks to a comprehensive range of automatic floatation systems, which increase verge mowing speeds, reduce operator input, and deliver a fast, effective cut without scalping.

Professional verge mowing contractors tackle thousands of miles of grass cutting a year so McConnel's four distinct floatation modes can make a huge impact on productivity by increasing verge mowing speeds by as much as 4.5 times.

Each mode offers advanced functionality, with the top-of-the-range Easy Drive System setting new standards for speed, safety and comfort, as well proving unbeatable in the most challenging conditions.

By raising working speeds from 4km/h to as much as 18km/h, the systems can dramatically increase verge mowing productivity whilst reducing the strain on operator and machine.



ANGLE FLOAT

Enables the cutting head to automatically follow the contours of the ground in a horizontal plane reducing the amount of manual input required and preventing fatigue.

Available on all McConnel Power Arms (except the Swingtrim).



FASTER, SMARTER, SAFER – MCCONNEL GIVES

LIFT FLOAT

Enables the cutting head to automatically follow the contours of the ground in a vertical plane, reducing the amount of manual input required and preventing fatigue.

- Automatically follows ground contours without the need for constant operator input
- Pressurised accumulator system
- 300mm of floatation travel
- Manual ground pressure adjustment
- Produces uniform cut and minimises risk of scalping
- Protects flails and Power Arm from excessive wear



Lift float **ON**



Lift float **OFF**

NO FLOAT

Requires continuous manual input - slowing down verge mowing speeds to around 4km/h.

4*
km/h

LIFT FLOAT

Automatic contour-following takes the strain off the operator and machines while increasing working speeds.

8*
km/h

ADVANCED FLOAT

Faster, more responsive contour-following and a greater range of floatation travel.

15*
km/h

EASY DRIVE SYSTEM

Award-winning floatation technology that delivers the best results and thrives in undulating terrain.

18*
km/h

*Dependent on machine and conditions.

VERGE MOWING PROFESSIONALS A CUTTING EDGE

ADVANCED FLOAT

Incorporates all the benefits of lift float, but adds a suite of extra features including unlimited floatation travel. Advanced Float automatically adjusts the flailhead position 30 times a second to ensure faster working speeds and reduce manual input in undulating terrain.

- Automatically adjusts to ground contours 30 times a second
- Electronic pressure sensing system
- Unlimited floatation travel
- Manual ground pressure adjustment
- Returns back into working position automatically
- Produces uniform cut and minimises risk of scalping
- Protects flails and Power Arm from excessive wear

EASY DRIVE SYSTEM (EDS)

McConel's elite floatation system and winner of the Queens Award for Innovation. EDS delivers faster 'hands-free' verge mowing speeds in undulating terrain and dramatically reduces both operator input and fatigue.

- Automatically adjusts to ground contours 30 times a second
- Electronic pressure sensing system
- Unlimited floatation travel
- Automatic ground pressure adjustment
- Automatic reach compensation
- Three different ground condition settings – Soft/Medium/Hard
- Returns back into working position automatically
- Angle float as standard
- Verge mowing speeds of up to 18km/h



HYDRAULIC FEATURES & UPGRADES

BOOSTING PRODUCTIVITY, PROTECTING YOUR MACHINE



Integrated Oil Cooler

OIL COOLER KIT

The Oil Cooler Kit improves the machine's performance and prolongs oil life in the most arduous conditions.

- Available on most Power Arms

DUAL DIRECTION ROTOR

Power Arms with totally independent hydraulics feature dual direction cutting, which allows the rotor to spin both anti-clockwise and clockwise. The direction of the rotor can be changed quickly and easily from the cab using a single button (or lever) on the Power Arm control system.

- Anti-clockwise 'downhill' cutting is the most popular way to cut hedges since it delivers a heavy-duty cut and ensures the mulch is retained within the hedgerow, reducing debris and promoting growth
- Clockwise or 'uphill' cutting produces a cleaner cut and a more attractive finish

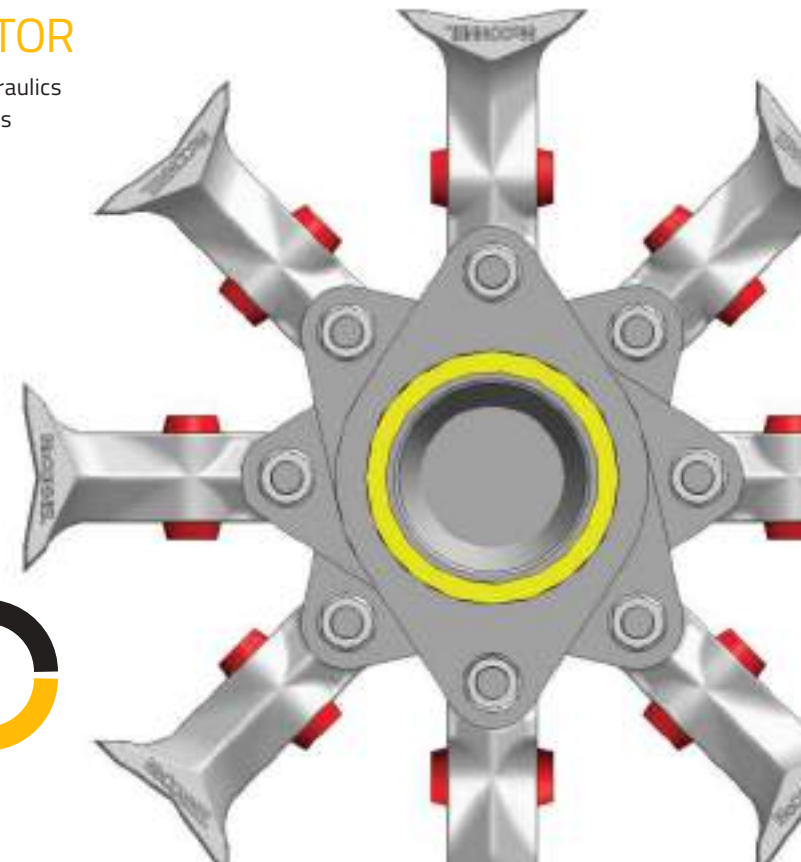



ADDITIONAL HYDRAULIC SERVICES

Incorporated into the machine's hydraulics and control system, these additional services expand the functionality of the Power Arm and are essential for controlling such services as:

- Hydraulic front hood
- Hydraulic roller
- Orbitor bracket
- Ditch and grip cleaner

SOFT START ROTOR ENGAGEMENT

Conventional machines feature all-on and all-off rotor engagement which puts a heavy strain on the machine when it is first fired up. SoftStart has a gradual transition to full power over six seconds, protecting parts and enhancing the lifespan of the machine.



POWERBOOST

McConel's intelligent hydraulics system increases the speed of Power Arm movements to three times the norm, making it ideal for professional contractors working around roadside obstacles or in varied terrain.

- 200% increase in hydraulic oil pressure delivers faster working speeds and eradicates power lag
- Precision enhanced by a progressive sensitivity setting which gradually increases arm speed the further the joystick is extended

“ POWERBOOST is the future – it makes your Power Arm faster and more responsive - and there is a significant difference in the power delivered to the flailhead. It makes a huge difference when working around obstacles. Rival machines feel like they're working in slow motion compared to POWERBOOST.

Chris Harvey, Suffolk contractor

POWER ARM SAFETY EQUIPMENT & PRODUCTIVITY

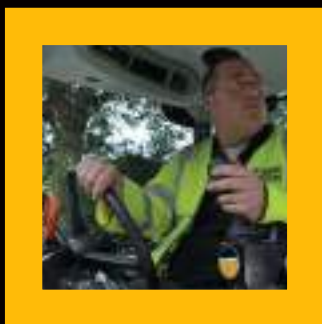

Improve your machine with an advanced suite of features to enhance safety, durability and performance.

DEBRIS BLOWER

Hydraulically driven blower cleans hedge trimmings and grass cuttings from highway.

- Hydraulically driven
- Fully adjustable
- Retro fit possible
- Controlled from cab
- Available on most Power Arms



TOP RIGHT: Integrated Debris Blower
INSET: External Debris Blower

SAFETY EQUIPMENT

ROAD LIGHTING KIT

All machinery should be installed with lighting kits if used on roads and when transported on highways.

- Improves visibility
- Helps prevent accidents
- Conforms to regulations
- Available on most Power Arms

LEFT: Front-Mounted Lighting Kit



POWER SLEW

Enables the arm to rotate 100 degrees backwards from the working position.

- Ensures the arm can be folded into a safe, compact transport position
- Enables operators to cut behind them which is ideal when cutting out corners in hedgerows

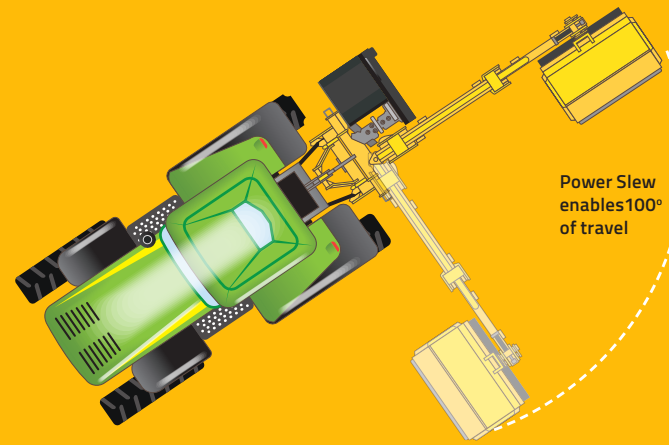

CUSHIONED TOP LINK

Features a heavy-duty rubber stopper to protect the Power Arm in transit and reduce shock-loading on the tractor.



Hydraulic safety breakaway enables the Power Arm to break backwards and upwards on contact with an obstacle

MAGNETIC WARNING ARROW

High visibility warning arrow improves visibility to prevent accidents and possible injury. Magnetically attaches to Power Arm guards and can be flipped to hide the arrow when in transport.

- Improves visibility
- Helps prevent accidents
- Magnetic attachment
- Conforms to regulations
- Available on most Power Arms

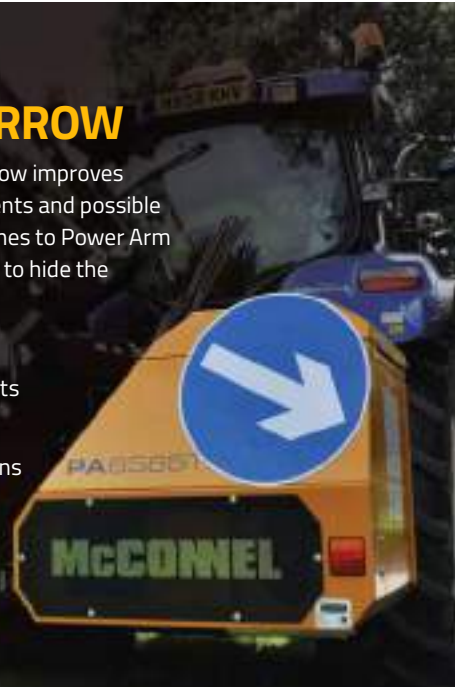

HYDRAULIC SAFETY BREAKAWAY

Safety breakaway is an innovative system which protects the Power Arm and the cutting attachment if it comes into contact with an obstacle. The system is standard on all models. (A mechanical version is fitted for models without Power Slew).

- Enables the Power Arm to break backwards and upwards on contact to prevent damage to the Power Arm, tractor, and foreign objects
- Rapid-response reduces scalping on the ground
- Automatically returns to the working position eliminating the need for a manual reset



CAB PROTECTION

The cab protection system safeguards the roof of the tractor from possible damage by preventing the arms coming into contact with it in transport, or when the arms are being manoeuvred directly behind the tractor.

The system consists of a specially engineered bracket which is attached to the machine's rocker and an adjustable strut and socket that bolts to the main frame of the machine.

POWER ARM PRODUCTIVITY

CREATED FOR PROFESSIONALS

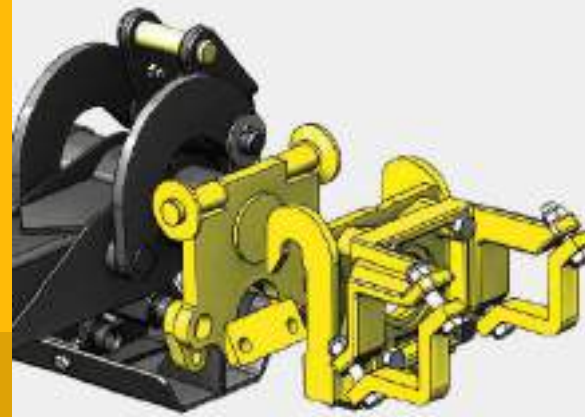

QUICK-ATTACH BRACKET

A quick-attach head stock and connecting bracket enable fast, safe and easy connection of flailheads and working attachments to the Power Arm. The system locks securely in place with a bolt kit and is available with optional quick-release couplings.



HYDRAULIC ROLLER

Enables operator to change the height of the roller via the in-cab controls. Ideal for switching between hedge-cutting and bank maintenance.

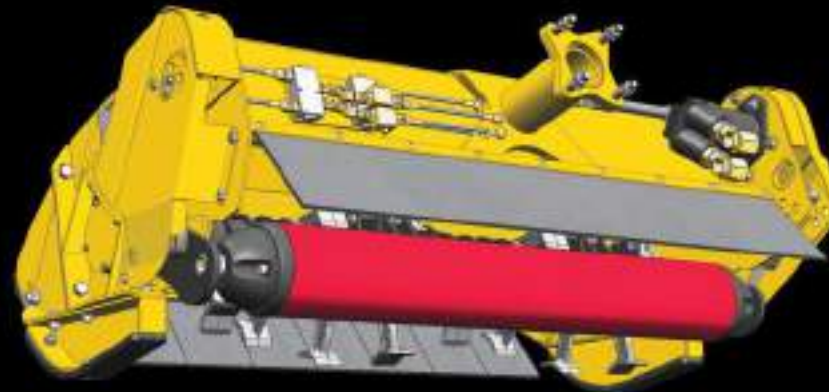

CUSHIONED ROLLER

Designed specifically for verge mowing, the cushioned roller is wrapped with a thick layer of rubber to absorb vibration, reduce wear and improve performance.



HYDRAULIC FRONT HOOD

Forestry flailhead can be specified with hydraulic front hood for clear flow of material to the rotor.



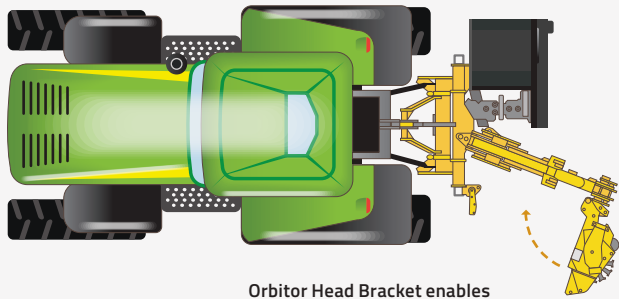

Orbitor Head Bracket enables an extra angle of movement

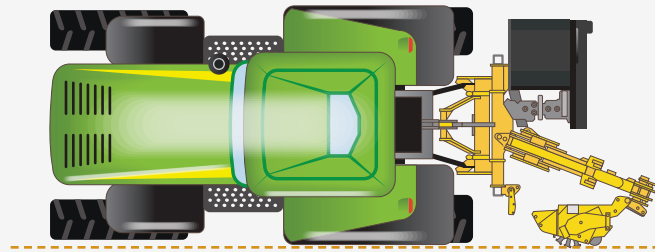

Orbitor Head Bracket allows Power Arm cutting operation within the tractor width



GREATER FLEXIBILITY IN CONFINED ENVIRONMENTS

ORBITOR HEAD BRACKET

Fitted between the cutting attachment and the dipper arm for an extra angle of movement, the orbitor bracket is an essential tool for hedge-cutting in narrow lanes where it increases manoeuvrability.

- Powered by a single ram fitted within the bracket for enhanced protection
- Enables the Power Arm to cut within the width of the tractor (when the arm is fitted with Power Slew)
- Improves cutting head geometry

Designed for working in confined environments, the Orbitor Head Bracket is exclusive to McConnell and enables operators who need a long reach armset to cut close-in to the tractor.



Normal position



Orbitor fully extended



POWER ARM PRODUCTIVITY

UNRIVALLED PRECISION



PARALLEL ARM GEOMETRY

This feature enables the operator to adjust the reach of the machine arms, without the need to continuously adjust the 'lift' service in order to compensate for the change in head pivot height - as would be the case with conventional arm geometry.

This is a standard feature on all McConnell Power Arms (except Swingtrim, Versi and Eco-series).

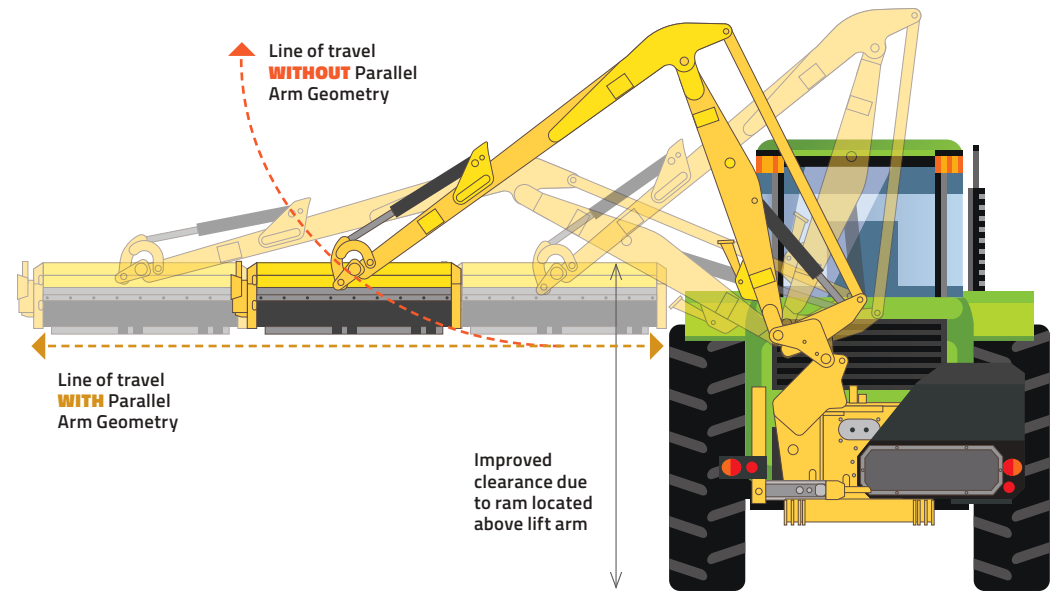

BENEFITS

- Maintains present height of flailhead regardless of reach
- Only one control input required
- Improves 'over-fence' clearance
- Ideal for 'topping out' hedges
- Improved arm geometry
- Heavy duty construction
- Standard on most Power Arms



McConnell's arm geometry is extremely precise and that makes the machine much easier to control and manoeuvre."

Graham Dix, Oxford City Council

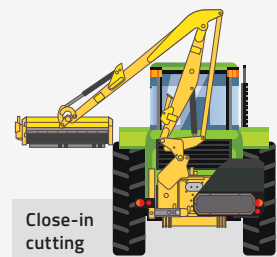
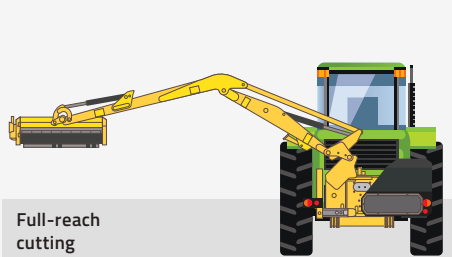

Close-in cutting



Straight-up cutting

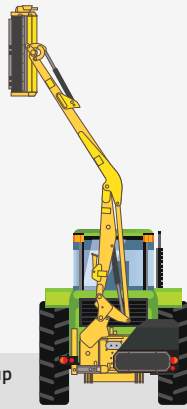

'Straight-up' cutting close to tractor

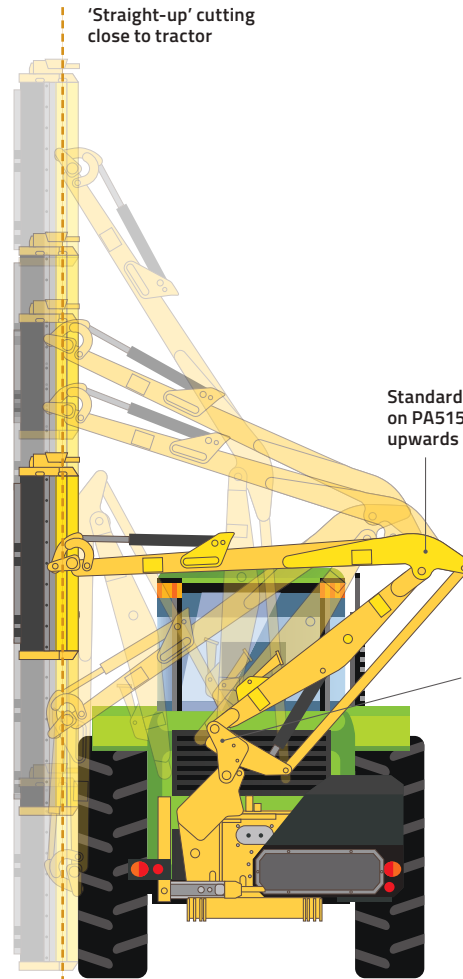

Close-in cutting position

BENEFITS

- Straight-up cutting close in to tractor
- Excellent over-fence clearance
- Improved down-bank geometry
- Ideal for cutting in narrow lanes
- Tried and tested technology
- Heavy duty construction
- Standard on 55-series upwards



HY-REACH GEOMETRY

Hy-reach arm geometry enables the cutting attachment to cut close in to the tractor at any height within the cutting range, ideal for cutting hedges at all heights in narrow lanes and other situations where space is at a premium. The high positioning of the rocker pillar also gives excellent over-fence clearance and down-bank reach.

POWER ARM RANGES

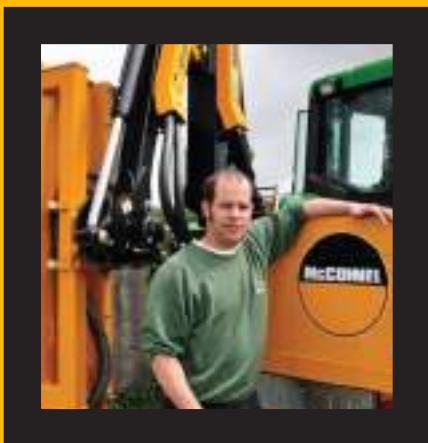

From lightweight, compact machines perfect for cutting in confined spaces to specialist embankment mowers with a dual telescopic arm and 9.0 metre reach, McConnell offers the most comprehensive range of Power Arms in the world.

Each series has been specially created to fill a precise niche, so whether you're a small-scale farmer cutting hedgerows as a side-line or a professional contractor working full-time maintaining highway verges, McConnell has the perfect machine for you.

With 13 series and a choice of 51 different models, and thousands of build options, McConnell can create a machine that feels tailor-made to suit your business.





SWINGTRIM REACH 3.5M



30 SERIES REACH 3.4 - 4.3M



35 SERIES REACH 4.8 - 5.1M



45 SERIES REACH 4.7 - 5.0M



55 SERIES REACH 5.1 - 5.5M



60 SERIES REACH 5.3 - 5.8M



67 SERIES REACH 5.5 - 7.0M



72 SERIES REACH 5.5 - 7.0M



75 SERIES REACH 5.6 - 8.0M



77 SERIES REACH 5.5 - 7.0M



85 SERIES REACH 6.0 - 9.0M



VERSI SERIES REACH 3.4 - 5.5M



POWER ARM

SWINGTRIM

SWINGTRIM - 3.5m (11'6") reach

SWINGTRIM

Advanced Controls

	SWINGTRIM
Cable Control	<input type="checkbox"/>
Motion Mini	<input type="checkbox"/>
Motion	—
Evolution	—
Revolution Including Easy Drive System (EDS)	—
Two-way Rotor Engagement - Cable Control (CRC)	<input type="checkbox"/>
Two-way Rotor Engagement - Electric Control (ERC)*	<input type="checkbox"/>

Mounting

Front 3-Point Mounting Including Stabiliser	<input type="checkbox"/>
Front DIN Plate Mounting	<input type="checkbox"/>
Rear 3-Point Mounting Including Stabiliser	<input type="checkbox"/>
Rear 3-Point to 4-Point Hitch Stabiliser Kit	—
Rear 3-Point to 5-Point Axle Mounting Kit**	—
Rear 5-Point Rigid Frame, Axle Mounting Kit**	—

Armsets

Straight Armset	■
Midcut Armset	—
Telescopic Armset	—
Variable Forward Reach Armset (VFR)	—
Telescopic-Variable Forward Reach Armset (T-VFR)	—
Parallel Arm Geometry	—

Hydraulics

Horsepower	6hp
System Type	—
Pump Type	—
Total Flow Rate l/min	11
Arm Circuit Flow Rate l/min	—
Attachment Circuit Flow Rate l/min	—
Oil Tank Capacity	—
Oil Cooler	—
Totally Independent Hydraulic System	<input type="checkbox"/>

Hydraulic Upgrades

Angle Float Kit	—
Lift Float Kit	—
Advanced Float Kit (only on EVOLUTION controls)	—
EDS (only on REVOLUTION controls)	—
PowerBoost (75 l/min Arm Circuit Flow Rate)	—
Additional Hydraulic Services	—

Safety Equipment

External Debris Blower	—
Integrated Debris Blower	—
Road Lighting Kit	—
Warning Arrow Kit	—
Window Guards	■
Cab Protection Kit	—
Safety Breakaway	■
Power Slew	—
Cushioned Top Link	—

Tractor Requirements

Minimum Tractor Weight	550kg
Minimum Tractor Horsepower	15hp

Specification

Machine Weight #	192kg
Left and Right-Hand Build Options	■

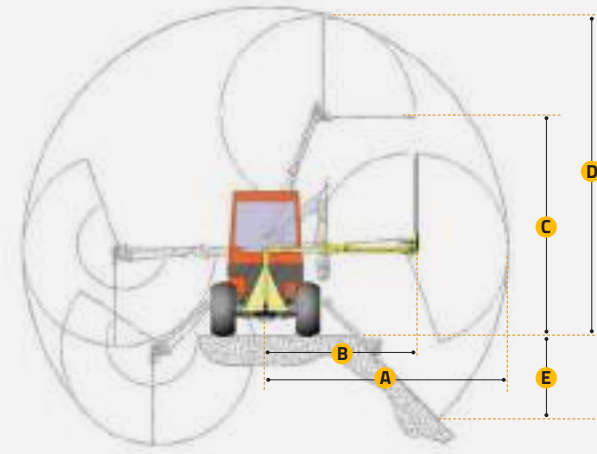

REACH DIMENSIONS

	SWINGTRIM
A	3.5m / 11' 6"
B	2.7m / 8' 10"
C	3.6m / 11' 10"
D	5.1m / 16' 9"
E	1.6m / 5' 3"

POWER ARM ATTACHMENTS

Multisaw	SWINGTRIM
1.40m Multisaw Compact 1400 - 80mm	<input type="checkbox"/>
2.10m Multisaw Compact 2100 - 80mm	<input type="checkbox"/>
2.80m Multisaw Compact 2800 - 80mm	<input type="checkbox"/>
Cutterbar	SWINGTRIM
1.20m Swingtrim Cutter Bar - SD - 30mm	■
1.50m Swingtrim Cutter Bar - SD - 30mm	<input type="checkbox"/>

■ Standard Equipment □ Optional Equipment — Not available

SWINGTRIM

Compact, light and manoeuvrable, the Swingtrim has been created for contractors and local government teams working in the amenities, landscape, and ground-care sectors.

- 3.5m Reach
- 2 Advanced control options
- 3 Mounting systems
- 1 Armset option
- 5 Attachment options



* Including SoftStart ** Excluding axle brackets & latches # Depending on specification, excluding attachment & oil



POWER ARM

30 SERIES

PA3430 - 3.4m (11' 2") reach

PA3530 Skid Steer / Utility Loader Series - 3.7m (12' 2") reach

PA4330 - 4.3m (14' 1") reach

30 SERIES

Advanced Controls	PA3430	PA3530	PA4330	PA4530	PA4830
Cable Control	<input type="checkbox"/>	<input type="checkbox"/>	<input type="checkbox"/>	—	—
Motion Mini	<input type="checkbox"/>	<input type="checkbox"/>	<input type="checkbox"/>	<input type="checkbox"/>	<input type="checkbox"/>
Motion	—	—	—	—	—
Evolution	—	—	—	—	—
Revolution Including Easy Drive System (EDS)	—	—	—	—	—
Two-way Rotor Engagement - Cable Control (CRC)	<input type="checkbox"/>	<input type="checkbox"/>	<input type="checkbox"/>	—	—
Two-way Rotor Engagement - Electric Control (ERC)*	<input type="checkbox"/>	<input type="checkbox"/>	<input type="checkbox"/>	<input type="checkbox"/>	<input type="checkbox"/>
Mounting					
Front 3-Point Mounting Including Stabiliser	<input type="checkbox"/>	<input type="checkbox"/>	<input type="checkbox"/>	<input type="checkbox"/>	<input type="checkbox"/>
Front DIN Plate Mounting	<input type="checkbox"/>	<input type="checkbox"/>	<input type="checkbox"/>	<input type="checkbox"/>	—
Rear 3-Point Mounting Including Stabiliser	<input type="checkbox"/>	—	<input type="checkbox"/>	—	<input type="checkbox"/>
Rear 3-Point to 4-Point Hitch Stabiliser Kit	—	—	—	—	—
Rear 3-Point to 5-Point Axle Mounting Kit**	—	—	—	—	—
Rear 5-Point Rigid Frame, Axle Mounting Kit**	—	—	—	—	—
Armsets					
Straight Armset	■	■	■	■	■
Midcut Armset	—	—	—	—	—
Telescopic Armset	—	—	—	—	—
Variable Forward Reach Armset (VFR)	—	—	—	—	■
Telescopic-Variable Forward Reach Armset (T-VFR)	—	—	—	—	—
Parallel Arm Geometry	■	■	■	■	■
Hydraulics					
Horsepower	30hp	30hp	30hp	30hp	30hp
System Type	Gear	Gear	Gear	Gear	Gear
Pump Type	Aluminum	Aluminum	Aluminum	Aluminum	Aluminum
Total Flow Rate l/min	55.0	55.0	55.0	55.0	55.0
Arm Circuit Flow Rate l/min	9.0	9.0	9.0	9.0	9.0
Attachment Circuit Flow Rate l/min	46.0	46.0	46.0	46.0	46.0
Oil Tank Capacity	80ltrs	55ltrs	80ltrs	55ltrs	110ltrs
Oil Cooler	<input type="checkbox"/>	—	<input type="checkbox"/>	—	<input type="checkbox"/>
Totally Independent Hydraulic System	■	<input type="checkbox"/>	■	<input type="checkbox"/>	■
Hydraulic Upgrades					
Angle Float Kit	■	■	■	■	■
Lift Float Kit	<input type="checkbox"/>	<input type="checkbox"/>	<input type="checkbox"/>	<input type="checkbox"/>	<input type="checkbox"/>
Advanced Float Kit (only on EVOLUTION controls)	—	—	—	—	—
EDS (only on REVOLUTION controls)	—	—	—	—	—
PowerBoost (75 l/min Arm Circuit Flow Rate)	—	—	—	—	—
Additional Hydraulic Services	—	—	—	—	—
Safety Equipment					
External Debris Blower	—	—	—	—	—
Integrated Debris Blower	—	—	—	—	—
Road Lighting Kit	—	—	—	—	—
Warning Arrow Kit	<input type="checkbox"/>	<input type="checkbox"/>	<input type="checkbox"/>	<input type="checkbox"/>	<input type="checkbox"/>
Window Guards	■	■	■	■	■
Cab Protection Kit	—	—	—	—	—
Safety Breakaway	■	■	■	■	■
Power Slew	—	—	—	—	—
Cushioned Top Link	—	—	—	—	—
Tractor Requirements					
Minimum Tractor Weight	1,300kg	1,300kg	2,000kg	2,200kg	2,400kg
Minimum Tractor Horsepower	35hp	35hp	35hp	35hp	35hp
Specification					
Machine Weight #	421kg	405kg	458kg	475kg	481kg
Left and Right-Hand Build Options	<input type="checkbox"/>	<input type="checkbox"/>	<input type="checkbox"/>	<input type="checkbox"/>	<input type="checkbox"/>

* Including SoftStart ** Excluding axle brackets & latches # Depending on specification, excluding attachment & oil

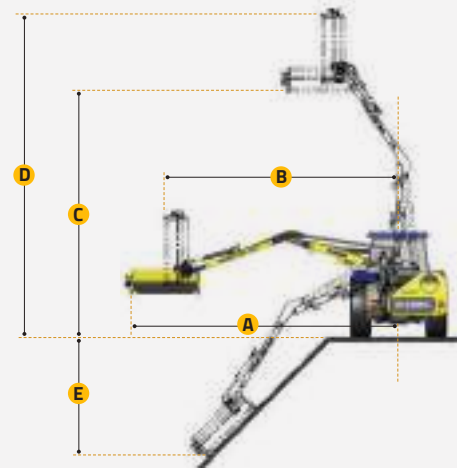

REACH DIMENSIONS

	PA3430	PA3530	PA4330	PA4530	PA4830
A	3.4m / 11' 2"	3.7m / 12' 2"	4.3m / 14' 1"	4.5m / 14' 9"	4.8m / 15' 9"
B	2.9m / 9' 6"	3.2m / 10' 6"	3.8m / 12' 6"	4.0m / 13' 2"	4.3m / 14' 1"
C	2.6m / 8' 6"	2.7m / 8' 10"	3.0m / 9' 10"	3.8m / 12' 6"	3.9m / 12' 10"
D	3.8m / 12' 6"	3.9m / 12'	4.2m / 13' 9"	4.9m / 16' 1"	5.5m / 18' 1"
E	1.4m / 4' 7"	1.4m / 4' 7"	1.8m / 5' 11"	2.2m / 7' 3"	2.4m / 7' 10"

POWER ARM FLAILHEADS

	PA3430	PA3530	PA4330	PA4530	PA4830
1.00m Supercut Flailhead	<input type="checkbox"/>	<input type="checkbox"/>	<input type="checkbox"/>	<input type="checkbox"/>	<input type="checkbox"/>
1.20m Supercut Flailhead	<input type="checkbox"/>	<input type="checkbox"/>	<input type="checkbox"/>	<input type="checkbox"/>	<input type="checkbox"/>
1.20m Multicut Flailhead - DD	—	—	—	—	—
1.20m Multicut Flailhead - BD	—	—	—	—	—
1.20m Tuffcut Flailhead - DD	—	—	—	—	—
1.20m Twincut Flailhead - DD	—	—	—	—	—
1.20m Omega Flailhead - DD	—	—	—	—	—
1.20m Omega Flailhead - BD	—	—	—	—	—
1.50m Multicut Flailhead - DD	—	—	—	—	—
1.50m Multicut Flailhead - BD	—	—	—	—	—
1.50m Twincut Flailhead - DD	—	—	—	—	—
1.50m Omega Flailhead - DD	—	—	—	—	—
1.50m Omega Flailhead - BD	—	—	—	—	—
1.60m Multicut Flailhead - DD	—	—	—	—	—
1.60m Multicut Flailhead - BD	—	—	—	—	—
1.60m Tuffcut Flailhead - DD	—	—	—	—	—
1.60m Omega Flailhead - DD	—	—	—	—	—
1.60m Omega Flailhead - BD	—	—	—	—	—
2.00m Multicut Flailhead - DD	—	—	—	—	—
2.00m Multicut Flailhead - BD	—	—	—	—	—
Flailhead Options					
Flailhead Skid Kit	<input type="checkbox"/>	<input type="checkbox"/>	<input type="checkbox"/>	<input type="checkbox"/>	<input type="checkbox"/>
Cushioned Grass Mowing Roller	—	—	—	—	—
Hydraulic Roller	—	—	—	—	—
Hydraulic Front Hood	—	—	—	—	—

■ Standard Equipment □ Optional Equipment — Not available

30 SERIES

Designed for the landscape, amenities and ground-care sectors, 30-series machines thrive in confined areas, parks and public grounds, and in sites with extensive street furniture.

They are also ideal for specialist contractors, local government, and small-scale farmers looking for a cost-effective hedgecutter for their own land.

- 5 Reach options from 3.4m to 4.8m
- 2 Advanced control options
- 3 Mounting options
- 1 Armset option
- 2 Floatation systems
- 10 Attachment options





POWER ARM

35 SERIES

PA4635-30 - 4.8m (15' 9") reach

PA5035-30 - 5.1m (16' 9") reach

35 SERIES

Advanced Controls	PA4635-30	PA5035-30
Cable Control	<input type="checkbox"/>	<input type="checkbox"/>
Motion Mini	<input type="checkbox"/>	<input type="checkbox"/>
Motion	—	—
Evolution	—	—
Revolution Including Easy Drive System (EDS)	—	—
One-way Rotor Engagement - Electric Control (ERC)	<input type="checkbox"/>	<input type="checkbox"/>
Two-way Rotor Engagement - Cable Control (CRC)	<input type="checkbox"/>	<input type="checkbox"/>
Two-way Rotor Engagement - Electric Control (ERC)	<input type="checkbox"/>	<input type="checkbox"/>
Mounting		
Front 3-Point Mounting Including Stabiliser	—	—
Front DIN Plate Mounting	—	—
Rear 3-Point Mounting Including Stabiliser	■	■
Rear 3-Point to 4-Point Hitch Stabiliser Kit	—	—
Rear 3-Point to 5-Point Axle Mounting Kit**	—	—
Rear 5-Point Rigid Frame, Axle Mounting Kit**	—	—
Armsets		
Straight Armset	■	■
Midcut Armset	—	—
Telescopic Armset	—	—
Variable Forward Reach Armset (VFR)	—	—
Telescopic-Variable Forward Reach Armset (T-VFR)	—	—
Parallel Arm Geometry	—	—
Hydraulics		
Horsepower	30hp	30hp
System Type	Gear	Gear
Pump Type	Aluminium	Aluminium
Total Flow Rate l/min	81.0	81.0
Arm Circuit Flow Rate l/min	12.8	12.8
Attachment Circuit Flow Rate l/min	68.2	68.2
Oil Tank Capacity	140ltrs	140ltrs
Oil Cooler	<input type="checkbox"/>	<input type="checkbox"/>
Totally Independent Hydraulic System	■	■
Hydraulic Upgrades		
Angle Float Kit	■	■
Lift Float Kit	■	■
Advanced Float Kit (only on EVOLUTION controls)	—	—
EDS (only on REVOLUTION controls)	—	—
PowerBoost (75 l/min Arm Circuit Flow Rate)	—	—
Additional Hydraulic Services	—	—
Safety Equipment		
External Debris Blower	<input type="checkbox"/>	<input type="checkbox"/>
Integrated Debris Blower	—	—
Road Lighting Kit	<input type="checkbox"/>	<input type="checkbox"/>
Warning Arrow Kit	<input type="checkbox"/>	<input type="checkbox"/>
Window Guards	■	■
Cab Protection Kit	—	—
Safety Breakaway	■	■
Power Slew	—	—
Cushioned Top Link	—	—
Tractor Requirements		
Minimum Tractor Weight	2,500kg	3,000kg
Minimum Tractor Horsepower	45hp	45hp
Specification		
Machine Weight †	563kg	572kg
Left and Right-Hand Build Options	<input type="checkbox"/>	<input type="checkbox"/>

* Including SoftStart ** Excluding axle brackets & latches † Depending on specification, excluding attachment & oil

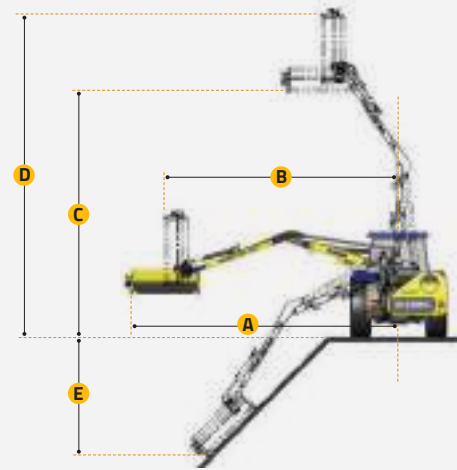

REACH DIMENSIONS

	PA4635-30	PA5035-30
A	4.8m / 15' 9"	5.1m / 16' 9"
B	4.6m / 15' 1"	4.9m / 16' 0"
C	3.2m / 10' 6"	3.4m / 11' 2"
D	5.3m / 17' 5"	5.6m / 18' 4"
E	1.9m / 6' 3"	2.1m / 6' 11"

POWER ARM FLAILHEADS

	PA4635-30	PA5035-30
1.00m Supercut Flailhead - DD	<input type="checkbox"/>	<input type="checkbox"/>
1.20m Supercut Flailhead - DD	<input type="checkbox"/>	<input type="checkbox"/>
1.20m Multicut Flailhead - DD	—	—
1.20m Multicut Flailhead - BD	—	—
1.20m Tuffcut Flailhead - DD	—	—
1.20m Twincut Flailhead - DD	—	—
1.20m Omega Flailhead - DD	—	—
1.20m Omega Flailhead - BD	—	—
1.50m Multicut Flailhead - DD	—	—
1.50m Multicut Flailhead - BD	—	—
1.50m Twincut Flailhead - DD	—	—
1.50m Omega Flailhead - DD	—	—
1.50m Omega Flailhead - BD	—	—
1.60m Multicut Flailhead - DD	—	—
1.60m Multicut Flailhead - BD	—	—
1.60m Tuffcut Flailhead - DD	—	—
1.60m Omega Flailhead - DD	—	—
1.60m Omega Flailhead - BD	—	—
2.00m Multicut Flailhead - DD	—	—
2.00m Multicut Flailhead - BD	—	—
Flailhead options		
Flailhead Skid Kit	<input type="checkbox"/>	<input type="checkbox"/>
Cushioned Grass Mowing Roller	—	—
Hydraulic Roller	—	—
Hydraulic Front Hood	—	—

■ Standard Equipment □ Optional Equipment — Not available

35 SERIES

Specifically designed for ground care, small scale farmers and local government sectors, the 35 series are robust and reliable compact machines.

Available in two reach sizes from 4.8m to 5.1m and powered by 30hp hydraulics the 35 series is suitable for use with smaller tractors of just 45 horsepower and above.

- 2 Reach options from 4.6m to 5.0m
- 2 Advanced control options
- 1 Mounting option
- 1 Armset system
- 2 Floatation systems
- 9 Attachment options





POWER ARM

45 SERIES

PA4745 - 4.7m (15' 5") reach

PA5045 - 5.0m (16' 5") reach

45 SERIES

Advanced Controls	PA4745	PA5045
Cable Control	<input type="checkbox"/>	<input type="checkbox"/>
Motion Mini	<input type="checkbox"/>	<input type="checkbox"/>
Motion	—	—
Evolution	—	—
Revolution Including Easy Drive System (EDS)	—	—
Two-way Rotor Engagement - Cable Control (CRC)	<input type="checkbox"/>	<input type="checkbox"/>
Two-way Rotor Engagement - Electric Control (ERC)*	<input type="checkbox"/>	<input type="checkbox"/>
Mounting		
Front 3-Point Mounting Including Stabiliser	—	—
Front DIN Plate Mounting	—	—
Rear 3-Point Mounting Including Stabiliser	■	■
Rear 3-Point to 4-Point Hitch Stabiliser Kit	—	—
Rear 3-Point to 5-Point Axle Mounting Kit**	—	—
Rear 5-Point Rigid Frame, Axle Mounting Kit**	—	—
Armsets		
Straight Armset	<input type="checkbox"/>	■
Midcut Armset	<input type="checkbox"/>	—
Telescopic Armset	—	—
Variable Forward Reach Armset (VFR)	—	—
Telescopic-Variable Forward Reach Armset (T-VFR)	—	—
Parallel Arm Geometry	■	■
Hydraulics		
Horsepower	45hp	45hp
System Type	Gear	Gear
Pump Type	Aluminium	Aluminium
Total Flow Rate l/min	90.0	90.0
Arm Circuit Flow Rate l/min	14.0	14.0
Attachment Circuit Flow Rate l/min	76.0	76.0
Oil Tank Capacity	180ltrs	180ltrs
Oil Cooler	<input type="checkbox"/>	<input type="checkbox"/>
Totally Independent Hydraulic System	■	■
Hydraulic Upgrades		
Angle Float Kit	<input type="checkbox"/>	<input type="checkbox"/>
Lift Float Kit	<input type="checkbox"/>	<input type="checkbox"/>
Advanced Float Kit (only on EVOLUTION controls)	—	—
EDS (only on REVOLUTION controls)	—	—
PowerBoost (75 l/min Arm Circuit Flow Rate)	—	—
Additional Hydraulic Services	—	—
Safety Equipment		
External Debris Blower	<input type="checkbox"/>	<input type="checkbox"/>
Integrated Debris Blower	—	—
Road Lighting Kit	<input type="checkbox"/>	<input type="checkbox"/>
Warning Arrow Kit	<input type="checkbox"/>	<input type="checkbox"/>
Window Guards	■	■
Cab Protection Kit	—	—
Safety Breakaway	■	■
Power Slew	—	—
Cushioned Top Link	■	■
Tractor Requirements		
Minimum Tractor Weight	2,500kg	2,750kg
Minimum Tractor Horsepower	60hp	60hp
Specification		
Machine Weight #	641kg	665kg
Left and Right-Hand Build Options	<input type="checkbox"/>	<input type="checkbox"/>

* Including SoftStart ** Excluding axle brackets & latches # Depending on specification, excluding attachment & oil

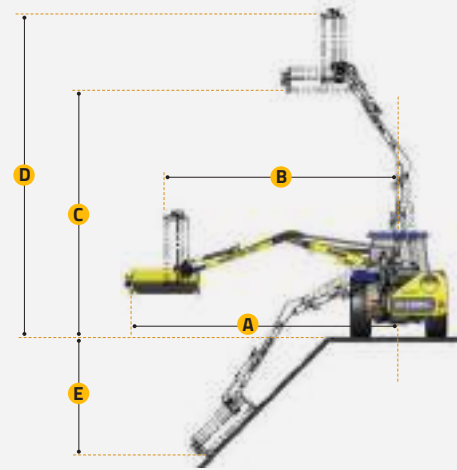

REACH DIMENSIONS

	PA4745	PA5045
A	4.7m / 15' 5"	5.0m / 16' 5"
B	4.1m / 13' 5"	4.45m / 14' 6"
C	4.0m / 13' 1"	4.3m / 14' 1"
D	5.3m / 17' 5"	5.8m / 19' 0"
E	2.0m / 6' 7"	2.2m / 7' 3"

POWER ARM FLAILHEADS

	PA4745	PA5045
1.00m Supercut Flailhead - DD	—	—
1.20m Supercut Flailhead - DD	<input type="checkbox"/>	<input type="checkbox"/>
1.20m Multicut Flailhead - DD	—	—
1.20m Multicut Flailhead - BD	—	—
1.20m Tuffcut Flailhead - DD	—	—
1.20m Twincut Flailhead - DD	—	—
1.20m Omega Flailhead - DD	—	—
1.20m Omega Flailhead - BD	—	—
1.50m Multicut Flailhead - DD	—	—
1.50m Multicut Flailhead - BD	—	—
1.50m Twincut Flailhead - DD	—	—
1.50m Omega Flailhead - DD	—	—
1.50m Omega Flailhead - BD	—	—
1.60m Multicut Flailhead - DD	—	—
1.60m Multicut Flailhead - BD	—	—
1.60m Tuffcut Flailhead - DD	—	—
1.60m Omega Flailhead - DD	—	—
1.60m Omega Flailhead - BD	—	—
2.00m Multicut Flailhead - DD	—	—
2.00m Multicut Flailhead - BD	—	—
Flailhead options		
Flailhead Skid Kit	<input type="checkbox"/>	<input type="checkbox"/>
Cushioned Grass Mowing Roller	—	—
Hydraulic Roller	—	—
Hydraulic Front Hood	—	—

■ Standard Equipment □ Optional Equipment — Not available

45 SERIES

Designed for grounds-keepers, small-scale farmers and contractors, and local government, 45-series machines offer a competitive feature-set, solid build-quality and a host of customisation options that sets them apart from rival machines.

Weighing in at just 641kg, the PA4745 is light and manoeuvrable and its low power requirement ensures it is compatible with tractors of just 60hp and above.

- 2 Reach options from 4.7m to 5.0m
- 2 Advanced control options
- 1 Mounting option
- 2 Armset options
- 2 Floatation systems
- 10 Attachment options





POWER ARM

55 SERIES

- PA5155 - 5.1m (16' 9") reach
- PA5455 - 5.4m (17' 9") reach
- PA5555-60 - 5.5m (18' 1") reach
- PA5755-60 - 5.7m (18' 9") reach

55 SERIES

Advanced Controls	PA5155	PA5455	PA5555-60	PA5755-60
Cable Control	<input type="checkbox"/>	<input type="checkbox"/>	<input type="checkbox"/>	<input type="checkbox"/>
Motion Mini	—	—	—	—
Motion	<input type="checkbox"/>	<input type="checkbox"/>	<input type="checkbox"/>	<input type="checkbox"/>
Evolution	<input type="checkbox"/>	<input type="checkbox"/>	<input type="checkbox"/>	<input type="checkbox"/>
Revolution Including Easy Drive System (EDS)	—	—	—	—
Two-way Rotor Engagement - Cable Control (CRC)	<input type="checkbox"/>	<input type="checkbox"/>	<input type="checkbox"/>	<input type="checkbox"/>
Two-way Rotor Engagement - Electric Control (ERC)*	<input type="checkbox"/>	<input type="checkbox"/>	<input type="checkbox"/>	<input type="checkbox"/>
Mounting				
Front 3-Point Mounting Including Stabiliser	—	—	—	—
Front DIN Plate Mounting	—	—	—	—
Rear 3-Point Mounting Including Stabiliser	■	■	■	■
Rear 3-Point to 4-Point Hitch Stabiliser Kit	<input type="checkbox"/>	<input type="checkbox"/>	<input type="checkbox"/>	<input type="checkbox"/>
Rear 3-Point to 5-Point Axle Mounting Kit**	—	—	—	—
Rear 5-Point Rigid Frame, Axle Mounting Kit**	—	—	—	—
Armsets				
Straight Armset	<input type="checkbox"/>	■	■	■
Midcut Armset	—	—	—	—
Telescopic Armset	—	—	—	—
Variable Forward Reach Armset (VFR)	<input type="checkbox"/>	—	—	—
Telescopic-Variable Forward Reach Armset (T-VFR)	—	—	—	—
Parallel Arm Geometry	■	■	■	■
Hydraulics				
Horsepower	55hp	55hp	60hp	60hp
System Type	Gear	Gear	Gear	Gear
Pump Type	Cast	Cast	Cast	Cast
Total Flow Rate l/min	122.0	122.0	122.0	122.0
Arm Circuit Flow Rate l/min	19.0	19.0	19.0	19.0
Attachment Circuit Flow Rate l/min	103.0	103.0	103.0	103.0
Oil Tank Capacity	180ltrs	180ltrs	180ltrs	180ltrs
Oil Cooler	<input type="checkbox"/>	<input type="checkbox"/>	■	■
Totally Independent Hydraulic System	■	■	■	■
Hydraulic Upgrades				
Angle Float Kit	<input type="checkbox"/>	<input type="checkbox"/>	<input type="checkbox"/>	<input type="checkbox"/>
Lift Float Kit	<input type="checkbox"/>	<input type="checkbox"/>	<input type="checkbox"/>	<input type="checkbox"/>
Advanced Float Kit (only on EVOLUTION controls)	—	—	—	—
EDS (only on REVOLUTION controls)	—	—	—	—
PowerBoost (75 l/min Arm Circuit Flow Rate)	—	—	—	—
Additional Hydraulic Services	<input type="checkbox"/>	<input type="checkbox"/>	<input type="checkbox"/>	<input type="checkbox"/>
Safety Equipment				
External Debris Blower	<input type="checkbox"/>	<input type="checkbox"/>	<input type="checkbox"/>	<input type="checkbox"/>
Integrated Debris Blower	—	—	—	—
Road Lighting Kit	<input type="checkbox"/>	<input type="checkbox"/>	■	■
Warning Arrow Kit	<input type="checkbox"/>	<input type="checkbox"/>	<input type="checkbox"/>	<input type="checkbox"/>
Window Guards	■	■	■	■
Cab Protection Kit	—	—	—	—
Safety Breakaway	■	■	■	■
Power Slew	■	■	■	■
Cushioned Top Link	—	—	—	—
Tractor Requirements				
Minimum Tractor Weight	3,000kg	3,500kg	3,500kg	3,500kg
Minimum Tractor Horsepower	70hp	70hp	70hp	70hp
Specification				
Machine Weight #	881kg	895kg	905kg	915kg
Left and Right-Hand Build Options	<input type="checkbox"/>	<input type="checkbox"/>	<input type="checkbox"/>	<input type="checkbox"/>

* Including SoftStart ** Excluding axle brackets & latches # Depending on specification, excluding attachment & oil

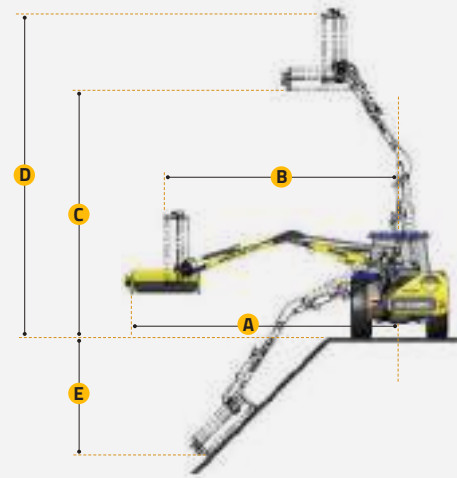

REACH DIMENSIONS

	PA5155	PA5455	PA5555-60	PA5755-60
A	5.1m / 16' 9"	5.4m / 17' 9"	5.5m / 18' 0"	5.7m / 18' 9"
B	4.5m / 14' 9"	4.8m / 15' 9"	4.9m / 16' 0"	5.1m / 16' 9"
C	4.5m / 14' 9"	4.7m / 15' 6"	4.8m / 15' 9"	5.0m / 16' 5"
D	5.9m / 19' 6"	6.2m / 20' 4"	6.3m / 20' 8"	6.5m / 21' 4"
E	2.1m / 6' 11"	2.3m / 7' 7"	2.4m / 7' 10"	2.5m / 8' 2"

POWER ARM FLAILHEADS

	PA5155	PA5455	PA5555-60	PA5755-60
1.00m Supercut Flailhead - DD	—	—	—	—
1.20m Supercut Flailhead - DD	—	—	—	—
1.20m Multicut Flailhead - DD	<input type="checkbox"/>	<input type="checkbox"/>	<input type="checkbox"/>	<input type="checkbox"/>
1.20m Multicut Flailhead - BD	<input type="checkbox"/>	<input type="checkbox"/>	<input type="checkbox"/>	<input type="checkbox"/>
1.20m Tuffcut Flailhead - DD	—	—	—	—
1.20m Twincut Flailhead - DD	—	—	—	—
1.20m Omega Flailhead - DD	<input type="checkbox"/>	<input type="checkbox"/>	<input type="checkbox"/>	<input type="checkbox"/>
1.20m Omega Flailhead - BD	<input type="checkbox"/>	<input type="checkbox"/>	<input type="checkbox"/>	<input type="checkbox"/>
1.50m Multicut Flailhead - DD	<input type="checkbox"/>	<input type="checkbox"/>	<input type="checkbox"/>	<input type="checkbox"/>
1.50m Multicut Flailhead - BD	<input type="checkbox"/>	<input type="checkbox"/>	<input type="checkbox"/>	<input type="checkbox"/>
1.50m Twincut Flailhead - DD	—	—	—	—
1.50m Omega Flailhead - DD	<input type="checkbox"/>	<input type="checkbox"/>	<input type="checkbox"/>	<input type="checkbox"/>
1.50m Omega Flailhead - BD	<input type="checkbox"/>	<input type="checkbox"/>	<input type="checkbox"/>	<input type="checkbox"/>
1.60m Multicut Flailhead - DD	—	—	—	—
1.60m Multicut Flailhead - BD	—	—	—	—
1.60m Tuffcut Flailhead - DD	—	—	—	—
1.60m Omega Flailhead - DD	—	—	—	—
1.60m Omega Flailhead - BD	—	—	—	—
2.00m Multicut Flailhead - DD	—	—	—	—
2.00m Multicut Flailhead - BD	—	—	—	—
Flailhead				
Flailhead Skid Kit	<input type="checkbox"/>	<input type="checkbox"/>	<input type="checkbox"/>	<input type="checkbox"/>
Cushioned Grass Mowing Roller	—	—	—	—
Hydraulic Roller	<input type="checkbox"/>	<input type="checkbox"/>	<input type="checkbox"/>	<input type="checkbox"/>
Hydraulic Front Hood	—	—	—	—

■ Standard Equipment Optional Equipment — Not available

55 SERIES

Designed for farmers, contractors and local government green maintenance teams, 55-series machines are robust and reliable with cast-iron pumps and gearboxes and high-capacity oil filters as standard.

Available with hy-reach and parallel arm geometry, hydraulic safety breakaway, Power Slew, and a wide range of attachments, the 55-series offers enhancements that are the envy of other mainstream mid-range Power Arms.

- 4 Reach options from 5.1m to 5.7m
- 3 Advanced control options
- 2 Mounting options
- 2 Armset option
- 2 Floatation options
- 21 Attachment options





POWER ARM

55 SERIES ECO

PA5055 ECO - 5.0m (16' 5") reach
PA5555 ECO - 5.5m (18' 1") reach
PA6055 ECO - 6.0m (19' 8") reach

55 SERIES ECO

Advanced Controls	PA5055 ECO	PA5555 ECO	PA6055 ECO
Cable Control	<input type="checkbox"/>	<input type="checkbox"/>	<input type="checkbox"/>
Motion Mini	—	—	—
Motion	<input type="checkbox"/>	<input type="checkbox"/>	<input type="checkbox"/>
Evolution	—	—	—
Revolution Including Easy Drive System (EDS)	—	—	—
Two-way Rotor Engagement - Cable Control (CRC)	<input type="checkbox"/>	<input type="checkbox"/>	<input type="checkbox"/>
Two-way Rotor Engagement - Electric Control (ERC)*	<input type="checkbox"/>	<input type="checkbox"/>	<input type="checkbox"/>
Mounting			
Front 3-Point Mounting Including Stabiliser	—	—	—
Front DIN Plate Mounting	—	—	—
Rear 3-Point Mounting Including Stabiliser	■	■	■
Rear 3-Point to 4-Point Hitch Stabiliser Kit	<input type="checkbox"/>	<input type="checkbox"/>	<input type="checkbox"/>
Rear 3-Point to 5-Point Axle Mounting Kit**	—	—	—
Rear 5-Point Rigid Frame, Axle Mounting Kit**	—	—	—
Armsets			
Straight Armset	<input type="checkbox"/>	<input type="checkbox"/>	<input type="checkbox"/>
Midcut Armset	—	—	—
Telescopic Armset	—	—	—
Variable Forward Reach Armset (VFR)	—	—	—
Telescopic-Variable Forward Reach Armset (T-VFR)	—	—	—
Parallel Arm Geometry	—	—	—
Hydraulics			
Horsepower	55hp	55hp	55hp
System Type	Gear	Gear	Gear
Pump Type	Cast	Cast	Cast
Total Flow Rate l/min	122.0	122.0	122.0
Arm Circuit Flow Rate l/min	19.0	19.0	19.0
Attachment Circuit Flow Rate l/min	103.0	103.0	103.0
Oil Tank Capacity	180ltrs	180ltrs	180ltrs
Oil Cooler	<input type="checkbox"/>	<input type="checkbox"/>	<input type="checkbox"/>
Totally Independent Hydraulic System	■	■	■
Hydraulic Upgrades			
Angle Float Kit	■	■	■
Lift Float Kit	<input type="checkbox"/>	<input type="checkbox"/>	<input type="checkbox"/>
Advanced Float Kit (only on EVOLUTION controls)	—	—	—
EDS (only on REVOLUTION controls)	—	—	—
PowerBoost (75 l/min Arm Circuit Flow Rate)	—	—	—
Additional Hydraulic Services	<input type="checkbox"/>	<input type="checkbox"/>	<input type="checkbox"/>
Safety Equipment			
External Debris Blower	<input type="checkbox"/>	<input type="checkbox"/>	<input type="checkbox"/>
Integrated Debris Blower	—	—	—
Road Lighting Kit	<input type="checkbox"/>	<input type="checkbox"/>	<input type="checkbox"/>
Warning Arrow Kit	<input type="checkbox"/>	<input type="checkbox"/>	<input type="checkbox"/>
Window Guards	■	■	■
Cab Protection Kit	—	—	—
Safety Breakaway	■	■	■
Power Slew	■	■	■
Cushioned Top Link	—	—	—
Tractor Requirements			
Minimum Tractor Weight	3,000kg	3,500kg	4,000kg
Minimum Tractor Horsepower	70hp	70hp	70hp
Specification			
Machine Weight #	785kg	845kg	940kg
Left and Right-Hand Build Options	RH only	RH only	RH only

* Including SoftStart ** Excluding axle brackets & latches # Depending on specification, excluding attachment & oil

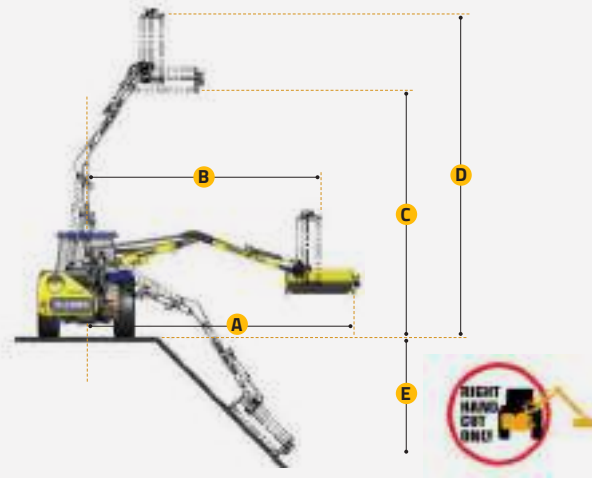

REACH DIMENSIONS

	PA5055 ECO	PA5555 ECO	PA6055 ECO
A	5.0m / 16' 5"	5.5m / 18' 1"	6.0m / 19' 8"
B	4.4m / 14' 5"	4.9m / 16' 1"	5.4m / 17' 9"
C	4.8m / 15' 9"	5.3m / 17' 5"	5.7m / 18' 8"
D	6.3m / 20' 8"	6.8m / 22' 4"	7.2m / 23' 7"
E	2.1m / 6' 11"	2.5m / 8' 2"	2.7m / 8' 10"

POWER ARM FLAILHEADS

	PA5055 ECO	PA5555 ECO	PA6055 ECO
1.00m Supercut Flailhead - DD	—	—	—
1.20m Supercut Flailhead - DD	—	—	—
1.20m Multicut Flailhead - DD	<input type="checkbox"/>	<input type="checkbox"/>	<input type="checkbox"/>
1.20m Multicut Flailhead - BD	<input type="checkbox"/>	<input type="checkbox"/>	<input type="checkbox"/>
1.20m Tuffcut Flailhead - DD	—	—	—
1.20m Twincut Flailhead - DD	—	—	—
1.20m Omega Flailhead - DD	<input type="checkbox"/>	<input type="checkbox"/>	<input type="checkbox"/>
1.20m Omega Flailhead - BD	<input type="checkbox"/>	<input type="checkbox"/>	<input type="checkbox"/>
1.50m Multicut Flailhead - DD	<input type="checkbox"/>	<input type="checkbox"/>	<input type="checkbox"/>
1.50m Multicut Flailhead - BD	<input type="checkbox"/>	<input type="checkbox"/>	<input type="checkbox"/>
1.50m Twincut Flailhead - DD	—	—	—
1.50m Omega Flailhead - DD	<input type="checkbox"/>	<input type="checkbox"/>	<input type="checkbox"/>
1.50m Omega Flailhead - BD	<input type="checkbox"/>	<input type="checkbox"/>	<input type="checkbox"/>
1.60m Multicut Flailhead - DD	—	—	—
1.60m Multicut Flailhead - BD	—	—	—
1.60m Tuffcut Flailhead - DD	—	—	—
1.60m Omega Flailhead - DD	—	—	—
1.60m Omega Flailhead - BD	—	—	—
2.00m Multicut Flailhead - DD	—	—	—
2.00m Multicut Flailhead - BD	—	—	—
Flailhead options			
Flailhead Skid Kit	<input type="checkbox"/>	<input type="checkbox"/>	<input type="checkbox"/>
Cushioned Grass Mowing Roller	—	—	—
Hydraulic Roller	<input type="checkbox"/>	<input type="checkbox"/>	<input type="checkbox"/>
Hydraulic Front Hood	—	—	—

■ Standard Equipment □ Optional Equipment — Not available

55 SERIES ECO

The ECO-series is designed for the export market and is only available in right-hand build. Designed for farmers, contractors and local government teams, ECO-series machines are easy to master; offer exceptional reach for a mid-range series; and are built to last with high-capacity oil filters and cast-iron pumps and gearboxes fitted as standard.

Advanced features include hydraulic safety breakaway, Power Slew and a choice of controllers.

- 3 Reach options from 5.0m to 6.0m
- 2 Advanced control options
- 2 Mounting options
- 1 Armset option
- 2 Floatation systems
- 21 Attachment options





POWER ARM

60 SERIES

PA5360 - 5.3m (17' 5") reach

PA5860 - 5.8m (19' 0") reach

60 SERIES

Advanced Controls	PA5360	PA5860
Cable Control	<input type="checkbox"/>	<input type="checkbox"/>
Motion Mini	—	—
Motion	<input type="checkbox"/>	<input type="checkbox"/>
Evolution	<input type="checkbox"/>	<input type="checkbox"/>
Revolution Including Easy Drive System (EDS)	<input type="checkbox"/>	<input type="checkbox"/>
Two-way Rotor Engagement - Cable Control (CRC)	<input type="checkbox"/>	<input type="checkbox"/>
Two-way Rotor Engagement - Electric Control (ERC)*	<input type="checkbox"/>	<input type="checkbox"/>
Mounting		
Front 3-Point Mounting Including Stabiliser	<input type="checkbox"/>	—
Front DIN Plate Mounting	<input type="checkbox"/>	—
Rear 3-Point Mounting Including Stabiliser	■	■
Rear 3-Point to 4-Point Hitch Stabiliser Kit	<input type="checkbox"/>	<input type="checkbox"/>
Rear 3-Point to 5-Point Axle Mounting Kit**	<input type="checkbox"/>	<input type="checkbox"/>
Rear 5-Point Rigid Frame, Axle Mounting Kit**	—	—
Armsets		
Straight Armset	<input type="checkbox"/>	<input type="checkbox"/>
Midcut Armset	—	—
Telescopic Armset	—	—
Variable Forward Reach Armset (VFR)	<input type="checkbox"/>	—
Telescopic-Variable Forward Reach Armset (T-VFR)	—	—
Parallel Arm Geometry	■	■
Hydraulics		
Horsepower	60hp	60hp
System Type	Gear	Gear
Pump Type	Cast	Cast
Total Flow Rate l/min	122.0	122.0
Arm Circuit Flow Rate l/min	19.0	19.0
Attachment Circuit Flow Rate l/min	103.0	103.0
Oil Tank Capacity	180ltrs	180ltrs
Oil Cooler	<input type="checkbox"/>	<input type="checkbox"/>
Totally Independent Hydraulic System	■	■
Hydraulic Upgrades		
Angle Float Kit	■ (Std on Cable)	■ (Std on Cable)
Lift Float Kit	<input type="checkbox"/>	<input type="checkbox"/>
Advanced Float Kit (only on EVOLUTION controls)	<input type="checkbox"/>	<input type="checkbox"/>
EDS (only on REVOLUTION controls)	<input type="checkbox"/>	<input type="checkbox"/>
PowerBoost (75 l/min Arm Circuit Flow Rate)	—	—
Additional Hydraulic Services	<input type="checkbox"/>	<input type="checkbox"/>
Safety Equipment		
External Debris Blower	<input type="checkbox"/>	<input type="checkbox"/>
Integrated Debris Blower	—	—
Road Lighting Kit	■	■
Warning Arrow Kit	<input type="checkbox"/>	<input type="checkbox"/>
Window Guards	■	■
Cab Protection Kit	—	—
Safety Breakaway	■	■
Power Slew	■	■
Cushioned Top Link	■	■
Tractor Requirements		
Minimum Tractor Weight	3,500kg	4,000kg
Minimum Tractor Horsepower	80hp	80hp
Specification		
Machine Weight #	1015kg	1060kg
Left and Right-Hand Build Options	<input type="checkbox"/>	<input type="checkbox"/>

* Including SoftStart ** Excluding axle brackets & latches # Depending on specification, excluding attachment & oil

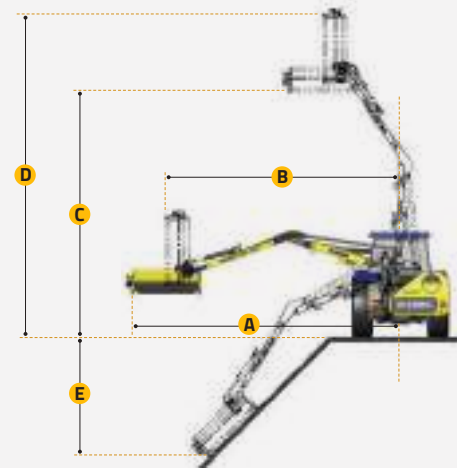

REACH DIMENSIONS

	PA5360	PA5860
A	5.3m / 17' 5"	5.8m / 19' 0"
B	4.7m / 15' 5"	5.2m / 17' 1"
C	4.8m / 15' 9"	5.2m / 17' 1"
D	6.3m / 20' 8"	6.8m / 22' 4"
E	2.5m / 8' 2"	2.7m / 8' 10"

POWER ARM FLAILHEADS

	PA5360	PA5860
1.00m Supercut Flailhead - DD	—	—
1.20m Supercut Flailhead - DD	—	—
1.20m Multicut Flailhead - DD	<input type="checkbox"/>	<input type="checkbox"/>
1.20m Multicut Flailhead - BD	<input type="checkbox"/>	<input type="checkbox"/>
1.20m Tuffcut Flailhead - DD	—	—
1.20m Twincut Flailhead - DD	—	—
1.20m Omega Flailhead - DD	<input type="checkbox"/>	<input type="checkbox"/>
1.20m Omega Flailhead - BD	<input type="checkbox"/>	<input type="checkbox"/>
1.50m Multicut Flailhead - DD	<input type="checkbox"/>	<input type="checkbox"/>
1.50m Multicut Flailhead - BD	<input type="checkbox"/>	<input type="checkbox"/>
1.50m Twincut Flailhead - DD	—	—
1.50m Omega Flailhead - DD	<input type="checkbox"/>	<input type="checkbox"/>
1.50m Omega Flailhead - BD	<input type="checkbox"/>	<input type="checkbox"/>
1.60m Multicut Flailhead - DD	—	—
1.60m Multicut Flailhead - BD	—	—
1.60m Tuffcut Flailhead - DD	—	—
1.60m Omega Flailhead - DD	—	—
1.60m Omega Flailhead - BD	—	—
2.00m Multicut Flailhead - DD	—	—
2.00m Multicut Flailhead - BD	—	—
Flailhead options		
Flailhead Skid Kit	<input type="checkbox"/>	<input type="checkbox"/>
Cushioned Grass Mowing Roller	<input type="checkbox"/>	<input type="checkbox"/>
Hydraulic Roller	<input type="checkbox"/>	<input type="checkbox"/>
Hydraulic Front Hood	—	—

■ Standard Equipment □ Optional Equipment — Not available

60 SERIES

Created for large-scale farmers, contractors and local government green maintenance teams, the 60-series is tough and durable and includes such enhancements as tapered seam-welded arms for strength and lightness, a cushioned top link for comfort in transport, and an axle-mounting option.

While retaining the price of a mid-range machine, the 60-series allows access to a series of performance-enhancing features such as McConnell's award winning Easy Drive System and state-of-the-art Revolution controls.

- 2 Reach options from 5.3m to 5.8m
- 4 Advanced control options
- 3 Mounting options
- 2 Armset options
- 4 Floatation services
- 22 Attachment options





POWER ARM

67 SERIES

- PA5567 - 5.5m (18'1") reach
- PA6067 - 6.0m (19'8") reach
- PA6567T - 6.5m (21'4") reach
- PA7067T - 7.0m (23'0") reach

67 SERIES

Advanced Controls	PA5567	PA6067	PA6567T	PA7067T
Cable Control	—	—	—	—
Motion Mini	—	—	—	—
Motion	<input type="checkbox"/>	<input type="checkbox"/>	<input type="checkbox"/>	<input type="checkbox"/>
Evolution	<input type="checkbox"/>	<input type="checkbox"/>	<input type="checkbox"/>	<input type="checkbox"/>
Revolution Including Easy Drive System (EDS)	<input type="checkbox"/>	<input type="checkbox"/>	<input type="checkbox"/>	<input type="checkbox"/>
Two-way Rotor Engagement - Cable Control (CRC)	—	—	—	—
Two-way Rotor Engagement - Electric Control (ERC)*	■	■	■	■
Mounting				
Front 3-Point Mounting Including Stabiliser	—	—	—	—
Front DIN Plate Mounting	—	—	—	—
Rear 3-Point Mounting Including Stabiliser	■	■	■	■
Rear 3-Point to 4-Point Hitch Stabiliser Kit	<input type="checkbox"/>	<input type="checkbox"/>	<input type="checkbox"/>	<input type="checkbox"/>
Rear 3-Point to 5-Point Axle Mounting Kit**	<input type="checkbox"/>	<input type="checkbox"/>	<input type="checkbox"/>	<input type="checkbox"/>
Rear 5-Point Rigid Frame, Axle Mounting Kit**	—	—	—	—
Armsets				
Straight Armset	<input type="checkbox"/>	<input type="checkbox"/>	—	—
Midcut Armset	—	—	—	—
Telescopic Armset	—	—	■	■
Variable Forward Reach Armset (VFR)	<input type="checkbox"/>	<input type="checkbox"/>	—	—
Telescopic-Variable Forward Reach Armset (T-VFR)	—	—	—	—
Parallel Arm Geometry	■	■	■	■
Hydraulics				
Horsepower	70hp	70hp	70hp	70hp
System Type	Gear	Gear	Gear	Gear
Pump Type	Cast	Cast	Cast	Cast
Total Flow Rate l/min	153.3	153.3	153.3	153.3
Arm Circuit Flow Rate l/min	25.0	25.0	25.0	25.0
Attachment Circuit Flow Rate l/min	128.0	128.0	128.0	128.0
Oil Tank Capacity	180ltrs	180ltrs	180ltrs	180ltrs
Oil Cooler	■	■	■	■
Totally Independent Hydraulic System	■	■	■	■
Hydraulic Upgrades				
Angle Float Kit	<input type="checkbox"/>	<input type="checkbox"/>	<input type="checkbox"/>	<input type="checkbox"/>
Lift Float Kit	<input type="checkbox"/>	<input type="checkbox"/>	<input type="checkbox"/>	<input type="checkbox"/>
Advanced Float Kit (only on EVOLUTION controls)	<input type="checkbox"/>	<input type="checkbox"/>	<input type="checkbox"/>	<input type="checkbox"/>
EDS (only on REVOLUTION controls)	<input type="checkbox"/>	<input type="checkbox"/>	<input type="checkbox"/>	<input type="checkbox"/>
PowerBoost (75 l/min Arm Circuit Flow Rate)	—	—	—	—
Additional Hydraulic Services	<input type="checkbox"/>	<input type="checkbox"/>	<input type="checkbox"/>	<input type="checkbox"/>
Safety Equipment				
External Debris Blower	<input type="checkbox"/>	<input type="checkbox"/>	<input type="checkbox"/>	<input type="checkbox"/>
Integrated Debris Blower	—	—	—	—
Road Lighting Kit	■	■	■	■
Warning Arrow Kit	<input type="checkbox"/>	<input type="checkbox"/>	<input type="checkbox"/>	<input type="checkbox"/>
Window Guards	■	■	■	■
Cab Protection Kit	<input type="checkbox"/>	<input type="checkbox"/>	<input type="checkbox"/>	<input type="checkbox"/>
Safety Breakaway	■	■	■	■
Power Slew	■	■	■	■
Cushioned Top Link	■	■	■	■
Tractor Requirements				
Minimum Tractor Weight	4,000kg	4,000kg	4,500kg	5,000kg
Minimum Tractor Horsepower	80hp	80hp	80hp	80hp
Specification				
Machine Weight #	1120kg	1152kg	1238kg	1275kg
Left and Right-Hand Build Options	<input type="checkbox"/>	<input type="checkbox"/>	<input type="checkbox"/>	<input type="checkbox"/>

* Including SoftStart ** Excluding axle brackets & latches # Depending on specification, excluding attachment & oil

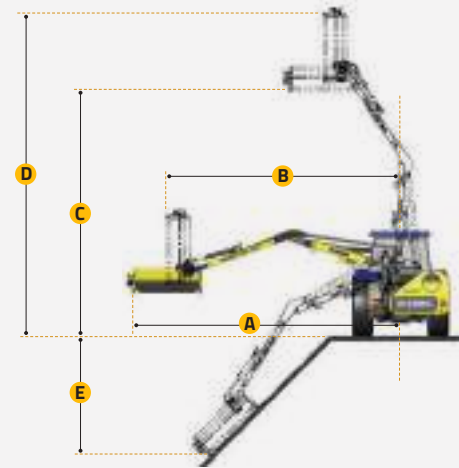

REACH DIMENSIONS

	PA5567	PA6067	PA6567T	PA7067T
A	5.5m / 18' 1"	6.0m / 19' 8"	6.5m / 21' 4"	7.0m / 23' 0"
B	4.9m / 16' 1"	5.4m / 17' 9"	5.9m / 19' 4"	6.4m / 21' 0"
C	5.3m / 17' 5"	5.7m / 18' 8"	5.7m / 18' 8"	6.1m / 19' 9"
D	6.7m / 22' 0"	7.1m / 23' 4"	7.1m / 23' 4"	7.1m / 23' 4"
E	2.4m / 7' 10"	2.8m / 9' 2"	3.2m / 10' 8"	3.5m / 11' 6"

POWER ARM FLAILHEADS

	PA5567	PA6067	PA6567T	PA7067T
1.00m Supercut Flailhead - DD	—	—	—	—
1.20m Supercut Flailhead - DD	—	—	—	—
1.20m Multicut Flailhead - DD	<input type="checkbox"/>	<input type="checkbox"/>	<input type="checkbox"/>	<input type="checkbox"/>
1.20m Multicut Flailhead - BD	<input type="checkbox"/>	<input type="checkbox"/>	<input type="checkbox"/>	<input type="checkbox"/>
1.20m Tuffcut Flailhead - DD	—	—	—	—
1.20m Twincut Flailhead - DD	<input type="checkbox"/>	<input type="checkbox"/>	—	—
1.20m Omega Flailhead - DD	<input type="checkbox"/>	<input type="checkbox"/>	<input type="checkbox"/>	<input type="checkbox"/>
1.20m Omega Flailhead - BD	<input type="checkbox"/>	<input type="checkbox"/>	<input type="checkbox"/>	<input type="checkbox"/>
1.50m Multicut Flailhead - DD	<input type="checkbox"/>	<input type="checkbox"/>	<input type="checkbox"/>	<input type="checkbox"/>
1.50m Multicut Flailhead - BD	<input type="checkbox"/>	<input type="checkbox"/>	<input type="checkbox"/>	<input type="checkbox"/>
1.50m Twincut Flailhead - DD	—	—	—	—
1.50m Omega Flailhead - DD	<input type="checkbox"/>	<input type="checkbox"/>	<input type="checkbox"/>	<input type="checkbox"/>
1.50m Omega Flailhead - BD	<input type="checkbox"/>	<input type="checkbox"/>	<input type="checkbox"/>	<input type="checkbox"/>
1.60m Multicut Flailhead - DD	<input type="checkbox"/>	<input type="checkbox"/>	—	—
1.60m Multicut Flailhead - BD	<input type="checkbox"/>	<input type="checkbox"/>	—	—
1.60m Tuffcut Flailhead - DD	—	—	—	—
1.60m Omega Flailhead - DD	<input type="checkbox"/>	<input type="checkbox"/>	—	—
1.60m Omega Flailhead - BD	<input type="checkbox"/>	<input type="checkbox"/>	—	—
2.00m Multicut Flailhead - DD	—	—	—	—
2.00m Multicut Flailhead - BD	—	—	—	—
Flailhead options				
Flailhead Skid Kit	<input type="checkbox"/>	<input type="checkbox"/>	<input type="checkbox"/>	<input type="checkbox"/>
Cushioned Grass Mowing Roller	<input type="checkbox"/>	<input type="checkbox"/>	<input type="checkbox"/>	<input type="checkbox"/>
Hydraulic Roller	<input type="checkbox"/>	<input type="checkbox"/>	<input type="checkbox"/>	<input type="checkbox"/>
Hydraulic Front Hood	—	—	—	—

■ Standard Equipment □ Optional Equipment — Not available

67 SERIES

Created for contractors and local government, the 67-series has the reach and power to tackle extensive verge-mowing and hedge-cutting duties. It also comes with a choice of advanced new control systems; Variable Forward Reach; and Twincut, the world's first dual rotor flailhead.

Built to last from super-strength Domex steel, 67-series machines are extremely robust and feature such enhancements as SoftStart rotor engagement, hydraulic safety breakaway, and a cushioned top link for increased longevity.

- 4 Reach options from 5.5m to 7.0m
- 3 Advanced control options
- 3 Mounting options
- 2 Armset options
- 4 Floatation services
- 27 Attachment options





POWER ARM

72 SERIES

- PA5572-70** - 5.5m (18'1") reach
- PA6072-70** - 6.0m (19'8") reach
- PA6572VFR-70** - 6.5m (21'4") reach
- PA6572T-70** - 6.5m (21'4") reach
- PA7072T-70** - 7.0m (23'0") reach

72 SERIES

Advanced Controls	PA5572-70	PA6072-70	PA6572VFR-70	PA6572T-70	PA7072T-70
Cable Control	—	—	—	—	—
Motion Mini	—	—	—	—	—
Motion	<input type="checkbox"/>	<input type="checkbox"/>	<input type="checkbox"/>	<input type="checkbox"/>	<input type="checkbox"/>
Evolution	<input type="checkbox"/>	<input type="checkbox"/>	<input type="checkbox"/>	<input type="checkbox"/>	<input type="checkbox"/>
Revolution Including Easy Drive System (EDS)	<input type="checkbox"/>	<input type="checkbox"/>	<input type="checkbox"/>	<input type="checkbox"/>	<input type="checkbox"/>
Two-way Rotor Engagement - Cable Control (CRC)	—	—	—	—	—
Two-way Rotor Engagement - Electric Control (ERC)*	■	■	■	■	■
Mounting					
Front 3-Point Mounting Including Stabiliser	—	—	—	—	—
Front DIN Plate Mounting	—	—	—	—	—
Rear 3-Point Mounting Including Stabiliser	■	■	■	■	■
Rear 3-Point to 4-Point Hitch Stabiliser Kit	<input type="checkbox"/>	<input type="checkbox"/>	<input type="checkbox"/>	<input type="checkbox"/>	<input type="checkbox"/>
Rear 3-Point to 5-Point Axle Mounting Kit**	<input type="checkbox"/>	<input type="checkbox"/>	<input type="checkbox"/>	<input type="checkbox"/>	<input type="checkbox"/>
Rear 5-Point Rigid Frame, Axle Mounting Kit**	—	—	—	—	—
Armsets					
Straight Armset	■	■	—	—	—
Midcut Armset	—	—	—	—	—
Telescopic Armset	—	—	—	■	■
Variable Forward Reach Armset (VFR)	<input type="checkbox"/>	<input type="checkbox"/>	■	—	—
Telescopic-Variable Forward Reach Armset (T-VFR)	—	—	—	—	—
Parallel Armset Geometry	■	■	■	■	■
Hydraulics					
Horsepower	70hp	70hp	70hp	70hp	70hp
System Type	Gear	Gear	Gear	Gear	Gear
Pump Type	Cast	Cast	Cast	Cast	Cast
Total Flow Rate l/min	160.0	160.0	160.0	160.0	160.0
Arm Circuit Flow Rate l/min	32.0	32.0	32.0	32.0	32.0
Attachment Circuit Flow Rate l/min	128.0	128.0	128.0	128.0	128.0
Oil Tank Capacity	180ltrs	180ltrs	180ltrs	180ltrs	180ltrs
High Capacity Oil Cooler	■	■	■	■	■
Totally Independent Hydraulic System	■	■	■	■	■
Hydraulic Upgrades					
Angle Float Kit	<input type="checkbox"/>	<input type="checkbox"/>	<input type="checkbox"/>	<input type="checkbox"/>	<input type="checkbox"/>
Lift Float Kit	<input type="checkbox"/>	<input type="checkbox"/>	<input type="checkbox"/>	<input type="checkbox"/>	<input type="checkbox"/>
Advanced Float Kit (only on EVOLUTION controls)	<input type="checkbox"/>	<input type="checkbox"/>	<input type="checkbox"/>	<input type="checkbox"/>	<input type="checkbox"/>
EDS (only on REVOLUTION controls)	<input type="checkbox"/>	<input type="checkbox"/>	<input type="checkbox"/>	<input type="checkbox"/>	<input type="checkbox"/>
PowerBoost (75 l/min Arm Circuit Flow Rate)	—	—	—	—	—
Additional Hydraulic Services	<input type="checkbox"/>	<input type="checkbox"/>	<input type="checkbox"/>	<input type="checkbox"/>	<input type="checkbox"/>
Safety Equipment					
External Debris Blower	—	—	—	—	—
Integrated Debris Blower	<input type="checkbox"/>	<input type="checkbox"/>	<input type="checkbox"/>	<input type="checkbox"/>	<input type="checkbox"/>
Road Lighting Kit	■	■	■	■	■
Warning Arrow Kit	<input type="checkbox"/>	<input type="checkbox"/>	<input type="checkbox"/>	<input type="checkbox"/>	<input type="checkbox"/>
Window Guards	■	■	■	■	■
Cab Protection Kit	<input type="checkbox"/>	<input type="checkbox"/>	<input type="checkbox"/>	<input type="checkbox"/>	<input type="checkbox"/>
Safety Breakaway	■	■	■	■	■
Power Slew	■	■	■	■	■
Cushioned Top Link	■	■	■	■	■
Tractor Requirements					
Minimum Tractor Weight	4,000kg	4,000kg	5,500kg	4,500kg	5,000kg
Minimum Tractor Horsepower	100hp	100hp	100hp	100hp	100hp
Specification					
Machine Weight #	1198kg	1217kg	1428kg	1319kg	1340kg
Left and Right-Hand Build Options	<input type="checkbox"/>	<input type="checkbox"/>	<input type="checkbox"/>	<input type="checkbox"/>	<input type="checkbox"/>

* Including SoftStart ** Excluding axle brackets & latches # Depending on specification, excluding attachment & oil

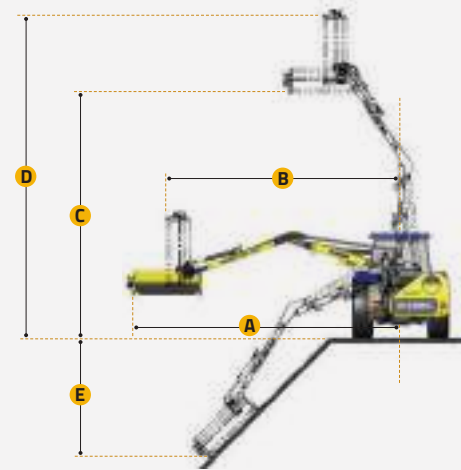

REACH DIMENSIONS

	PA5572-70	PA6072-70	PA6572VFR-70	PA6572T-70	PA7072T-70
A	5.5m / 18' 1"	6.0m / 19' 8"	6.5m / 21' 4"	6.5m / 21' 4"	7.0m / 23' 0"
B	4.9m / 16' 1"	5.4m / 17' 9"	5.9m / 19' 4"	5.9m / 19' 4"	6.4m / 21' 0"
C	5.1m / 16' 9"	5.6m / 18' 4"	6.2m / 20' 4"	6.0m / 19' 8"	6.5m / 21' 4"
D	6.7m / 22' 0"	7.1m / 23' 4"	7.6m / 24' 11"	7.5m / 24' 7"	8.0m / 26' 3"
E	2.5m / 8' 2"	2.8m / 9' 2"	3.2m / 10' 6"	3.2m / 10' 6"	3.5m / 11' 6"

POWER ARM FLAILHEADS

	PA5572-70	PA6072-70	PA6572VFR-70	PA6572T-70	PA7072T-70
1.00m Supercut Flailhead - DD	—	—	—	—	—
1.20m Supercut Flailhead - DD	—	—	—	—	—
1.20m Multicut Flailhead - DD	<input type="checkbox"/>	<input type="checkbox"/>	<input type="checkbox"/>	<input type="checkbox"/>	<input type="checkbox"/>
1.20m Multicut Flailhead - BD	<input type="checkbox"/>	<input type="checkbox"/>	<input type="checkbox"/>	<input type="checkbox"/>	<input type="checkbox"/>
1.20m Tuffcut Flailhead - DD	<input type="checkbox"/>	<input type="checkbox"/>	<input type="checkbox"/>	<input type="checkbox"/>	<input type="checkbox"/>
1.20m Tuffcut Flailhead - BD	<input type="checkbox"/>	<input type="checkbox"/>	<input type="checkbox"/>	<input type="checkbox"/>	<input type="checkbox"/>
1.20m Twincut Flailhead - DD	<input type="checkbox"/>	<input type="checkbox"/>	—	—	—
1.20m Omega Flailhead - DD	<input type="checkbox"/>	<input type="checkbox"/>	<input type="checkbox"/>	<input type="checkbox"/>	<input type="checkbox"/>
1.20m Omega Flailhead - BD	<input type="checkbox"/>	<input type="checkbox"/>	<input type="checkbox"/>	<input type="checkbox"/>	<input type="checkbox"/>
1.50m Multicut Flailhead - DD	<input type="checkbox"/>	<input type="checkbox"/>	<input type="checkbox"/>	<input type="checkbox"/>	<input type="checkbox"/>
1.50m Multicut Flailhead - BD	<input type="checkbox"/>	<input type="checkbox"/>	<input type="checkbox"/>	<input type="checkbox"/>	<input type="checkbox"/>
1.50m Twincut Flailhead - DD	<input type="checkbox"/>	<input type="checkbox"/>	—	—	—
1.50m Omega Flailhead - DD	<input type="checkbox"/>	<input type="checkbox"/>	<input type="checkbox"/>	<input type="checkbox"/>	<input type="checkbox"/>
1.50m Tuffcut Flailhead - DD	<input type="checkbox"/>	<input type="checkbox"/>	<input type="checkbox"/>	<input type="checkbox"/>	<input type="checkbox"/>
1.50m Tuffcut Flailhead - BD	<input type="checkbox"/>	<input type="checkbox"/>	<input type="checkbox"/>	<input type="checkbox"/>	<input type="checkbox"/>
1.50m Omega Flailhead - BD	<input type="checkbox"/>	<input type="checkbox"/>	<input type="checkbox"/>	<input type="checkbox"/>	<input type="checkbox"/>
1.60m Multicut Flailhead - DD	<input type="checkbox"/>	<input type="checkbox"/>	—	—	—
1.60m Multicut Flailhead - BD	<input type="checkbox"/>	<input type="checkbox"/>	—	—	—
1.60m Tuffcut Flailhead - DD	<input type="checkbox"/>	<input type="checkbox"/>	<input type="checkbox"/>	<input type="checkbox"/>	<input type="checkbox"/>
1.60m Tuffcut Flailhead - BD	<input type="checkbox"/>	<input type="checkbox"/>	<input type="checkbox"/>	<input type="checkbox"/>	<input type="checkbox"/>
1.60m Omega Flailhead - DD	<input type="checkbox"/>	<input type="checkbox"/>	—	—	—
1.60m Omega Flailhead - BD	<input type="checkbox"/>	<input type="checkbox"/>	—	—	—
2.00m Multicut Flailhead - DD	—	—	—	—	—
2.00m Multicut Flailhead - BD	—	—	—	—	—
Flailhead					
Flailhead Skid Kit	<input type="checkbox"/>	<input type="checkbox"/>	<input type="checkbox"/>	<input type="checkbox"/>	<input type="checkbox"/>
Cushioned Grass Mowing Roller	<input type="checkbox"/>	<input type="checkbox"/>	<input type="checkbox"/>	<input type="checkbox"/>	<input type="checkbox"/>
Hydraulic Roller	<input type="checkbox"/>	<input type="checkbox"/>	<input type="checkbox"/>	<input type="checkbox"/>	<input type="checkbox"/>
Hydraulic Front Hood ###	<input type="checkbox"/>	<input type="checkbox"/>	<input type="checkbox"/>	<input type="checkbox"/>	<input type="checkbox"/>

■ Standard Equipment □ Optional Equipment — Not available ### Excluding Twincut

72 SERIES

The McConel 72-Series Power Arms are designed for farmers, contractors, and local authorities, this Series features a 70hp hydraulic system with reach options from 5.5m to 7.0m, including Telescopic and VFR options.

Innovations such as an integrated debris blower, LED road lighting, and enhanced service access ensure optimal performance and convenience. With a comprehensive range of attachment, the 72-Series offers a versatile and reliable solution for vegetation management.

- 4 Reach options from 5.5m to 7.0m
- 3 Advanced control options
- 3 Mounting options
- 5 Armset options
- 4 Floatation services
- 27 Attachment options



Optional Integrated Debris Blower



POWER ARM

75 SERIES

- PA5675 - 5.6m (18' 4") reach
- PA6075 - 6.0m (19' 8") reach
- PA6475 - 6.4m (21') reach

75 SERIES

Advanced Controls	PA5675	PA6075	PA6475
Cable Control	—	—	—
Motion Mini	—	—	—
Motion	<input type="checkbox"/>	<input type="checkbox"/>	<input type="checkbox"/>
Evolution	<input type="checkbox"/>	<input type="checkbox"/>	<input type="checkbox"/>
Revolution Including Easy Drive System (EDS)	<input type="checkbox"/>	<input type="checkbox"/>	<input type="checkbox"/>
Two-way Rotor Engagement - Cable Control (CRC)	—	—	—
Two-way Rotor Engagement - Electric Control (ERC)*	■	■	■
Mounting			
Front 3-Point Mounting Including Stabiliser	—	—	—
Front DIN Plate Mounting	—	—	—
Rear 3-Point Mounting Including Stabiliser	■	■	■
Rear 3-Point to 4-Point Hitch Stabiliser Kit	<input type="checkbox"/>	<input type="checkbox"/>	<input type="checkbox"/>
Rear 3-Point to 5-Point Axle Mounting Kit**	<input type="checkbox"/>	<input type="checkbox"/>	<input type="checkbox"/>
Rear 5-Point Rigid Frame, Axle Mounting Kit**	<input type="checkbox"/>	<input type="checkbox"/>	<input type="checkbox"/>
Armsets			
Straight Armset	■	■	■
Midcut Armset	—	—	—
Telescopic Armset	—	—	—
Variable Forward Reach Armset (VFR)	<input type="checkbox"/>	<input type="checkbox"/>	<input type="checkbox"/>
Telescopic-Variable Forward Reach Armset (T-VFR)	—	—	—
Parallel Arm Geometry	■	■	■
Hydraulics			
Horsepower	70hp	70hp	70hp
System Type	Gear	Gear	Gear
Pump Type	Cast	Cast	Cast
Total Flow Rate l/min	160.0	160.0	160.0
Arm Circuit Flow Rate l/min	32.0	32.0	32.0
Attachment Circuit Flow Rate l/min	128.0	128.0	128.0
Oil Tank Capacity	200ltrs	200ltrs	200ltrs
Oil Cooler	■	■	■
Totally Independent Hydraulic System	■	■	■
Hydraulic Upgrades			
Angle Float Kit	■	■	■
Lift Float Kit	<input type="checkbox"/>	<input type="checkbox"/>	<input type="checkbox"/>
Advanced Float Kit (only on EVOLUTION controls)	<input type="checkbox"/>	<input type="checkbox"/>	<input type="checkbox"/>
EDS (only on REVOLUTION controls)	<input type="checkbox"/>	<input type="checkbox"/>	<input type="checkbox"/>
PowerBoost (75 l/min Arm Circuit Flow Rate)	—	—	—
Additional Hydraulic Services	<input type="checkbox"/>	<input type="checkbox"/>	<input type="checkbox"/>
Safety Equipment			
External Debris Blower	<input type="checkbox"/>	<input type="checkbox"/>	<input type="checkbox"/>
Integrated Debris Blower	—	—	—
Road Lighting Kit	■	■	■
Warning Arrow Kit	<input type="checkbox"/>	<input type="checkbox"/>	<input type="checkbox"/>
Window Guards	—	—	—
Cab Protection Kit	■	■	■
Safety Breakaway	■	■	■
Power Slew	■	■	■
Cushioned Top Link	■	■	■
Tractor Requirements			
Minimum Tractor Weight	5,000kg	5,000kg	5,000kg
Minimum Tractor Horsepower	120hp	120hp	120hp
Specification			
Machine Weight #	1695kg	1695kg	TBC
Left and Right-Hand Build Options	<input type="checkbox"/>	<input type="checkbox"/>	<input type="checkbox"/>

* Including SoftStart ** Excluding axle brackets & latches # Depending on specification, excluding attachment & oil

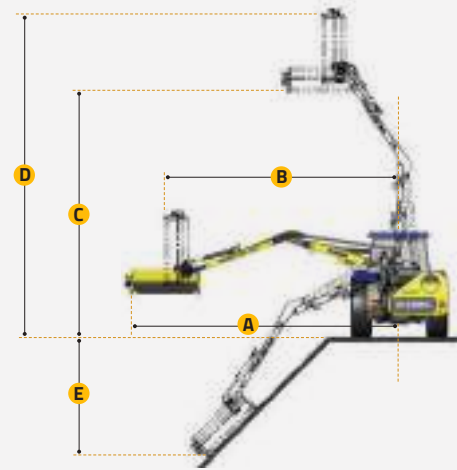

REACH DIMENSIONS

	PA5675	PA6075	PA6475
A	5.6m / 18' 4"	6.0m / 19' 8"	6.5m / 21' 4"
B	5.1m / 16' 9"	5.4m / 17' 9"	5.9m / 19' 4"
C	5.2m / 17' 1"	5.6m / 18' 4"	5.7m / 18' 8"
D	6.7m / 22'	7.0m / 22' 11"	7.1m / 23' 4"
E	2.4m / 7' 10"	2.8m / 9' 2"	3.0m / 9' 10"

POWER ARM FLAILHEADS

	PA5675	PA6085	PA6475
1.00m Supercut Flailhead - DD	—	—	—
1.20m Supercut Flailhead - DD	—	—	—
1.20m Multicut Flailhead - DD	<input type="checkbox"/>	<input type="checkbox"/>	<input type="checkbox"/>
1.20m Multicut Flailhead - BD	<input type="checkbox"/>	<input type="checkbox"/>	<input type="checkbox"/>
1.20m Tuffcut Flailhead - DD	—	<input type="checkbox"/>	—
1.20m Twincut Flailhead - DD	<input type="checkbox"/>	<input type="checkbox"/>	<input type="checkbox"/>
1.20m Omega Flailhead - DD	<input type="checkbox"/>	<input type="checkbox"/>	<input type="checkbox"/>
1.20m Omega Flailhead - BD	<input type="checkbox"/>	<input type="checkbox"/>	<input type="checkbox"/>
1.50m Multicut Flailhead - DD	<input type="checkbox"/>	<input type="checkbox"/>	<input type="checkbox"/>
1.50m Multicut Flailhead - BD	<input type="checkbox"/>	<input type="checkbox"/>	<input type="checkbox"/>
1.50m Twincut Flailhead - DD	—	<input type="checkbox"/>	—
1.50m Omega Flailhead - DD	<input type="checkbox"/>	<input type="checkbox"/>	<input type="checkbox"/>
1.50m Omega Flailhead - BD	<input type="checkbox"/>	<input type="checkbox"/>	<input type="checkbox"/>
1.60m Multicut Flailhead - DD	<input type="checkbox"/>	<input type="checkbox"/>	<input type="checkbox"/>
1.60m Multicut Flailhead - BD	<input type="checkbox"/>	<input type="checkbox"/>	<input type="checkbox"/>
1.60m Tuffcut Flailhead - DD	—	<input type="checkbox"/>	—
1.60m Omega Flailhead - DD	<input type="checkbox"/>	<input type="checkbox"/>	<input type="checkbox"/>
1.60m Omega Flailhead - BD	<input type="checkbox"/>	<input type="checkbox"/>	<input type="checkbox"/>
2.00m Multicut Flailhead - DD	<input type="checkbox"/>	<input type="checkbox"/>	<input type="checkbox"/>
2.00m Multicut Flailhead - BD	<input type="checkbox"/>	<input type="checkbox"/>	<input type="checkbox"/>
Flailhead options			
Flailhead Skid Kit	<input type="checkbox"/>	<input type="checkbox"/>	<input type="checkbox"/>
Cushioned Grass Mowing Roller	<input type="checkbox"/>	<input type="checkbox"/>	<input type="checkbox"/>
Hydraulic Roller	<input type="checkbox"/>	<input type="checkbox"/>	<input type="checkbox"/>
Hydraulic Front Hood	<input type="checkbox"/>	<input type="checkbox"/>	<input type="checkbox"/>

■ Standard Equipment □ Optional Equipment — Not available

75 SERIES

A rugged heavy-duty series designed for full-time contractors, the 75 Series is precision-engineered from Domex Steel and features a radical new oil tank and cooling system for peak performance in all conditions.

Available in six different reach sizes from 5.6m to 8.0m and powered by high-performance 70hp hydraulics, the new series is available with a suite of advanced features including the REVOLUTION Control System, EDS, and the Tele-VFR armset.

- 6 Reach options from 5.6m to 8.0m
- 3 Advanced control options
- 4 Mounting options
- 2 Armset options
- 4 Floatation services
- 28 Attachment options





POWER ARM

75 SERIES

PA6575T - 6.5m (21' 4") reach
PA7775T - 7.7m (25' 3") reach
PA8075T - 8.0m (26' 3") reach

75 SERIES

Advanced Controls	PA6575T	PA7775T	PA8075T
Cable Control	—	—	—
Motion Mini	—	—	—
Motion	<input type="checkbox"/>	<input type="checkbox"/>	<input type="checkbox"/>
Evolution	<input type="checkbox"/>	<input type="checkbox"/>	<input type="checkbox"/>
Revolution Including Easy Drive System (EDS)	<input type="checkbox"/>	<input type="checkbox"/>	<input type="checkbox"/>
Two-way Rotor Engagement - Cable Control (CRC)	—	—	—
Two-way Rotor Engagement - Electric Control (ERC)*	■	■	■
Mounting			
Front 3-Point Mounting Including Stabiliser	—	—	—
Front DIN Plate Mounting	—	—	—
Rear 3-Point Mounting Including Stabiliser	■	—	—
Rear 3-Point to 4-Point Hitch Stabiliser Kit	<input type="checkbox"/>	—	—
Rear 3-Point to 5-Point Axle Mounting Kit**	<input type="checkbox"/>	—	—
Rear 5-Point Rigid Frame, Axle Mounting Kit**	<input type="checkbox"/>	■	■
Armsets			
Straight Armset	—	—	—
Midcut Armset	—	—	—
Telescopic Armset	■	■	■
Variable Forward Reach Armset (VFR)	—	—	—
Telescopic-Variable Forward Reach Armset (T-VFR)	<input type="checkbox"/>	<input type="checkbox"/>	<input type="checkbox"/>
Parallel Arm Geometry	■	■	■
Hydraulics			
Horsepower	70hp	70hp	70hp
System Type	Gear	Gear	Gear
Pump Type	Cast	Cast	Cast
Total Flow Rate l/min	160.0	160.0	160.0
Arm Circuit Flow Rate l/min	32.0	32.0	32.0
Attachment Circuit Flow Rate l/min	128.0	128.0	128.0
Oil Tank Capacity	200ltrs	200ltrs	200ltrs
Oil Cooler	■	■	■
Totally Independent Hydraulic System	■	■	■
Hydraulic Upgrades			
Angle Float Kit	■	■	■
Lift Float Kit	<input type="checkbox"/>	<input type="checkbox"/>	<input type="checkbox"/>
Advanced Float Kit (only on EVOLUTION controls)	<input type="checkbox"/>	<input type="checkbox"/>	<input type="checkbox"/>
EDS (only on REVOLUTION controls)	<input type="checkbox"/>	<input type="checkbox"/>	<input type="checkbox"/>
PowerBoost (75 l/min Arm Circuit Flow Rate)	—	—	—
Additional Hydraulic Services	<input type="checkbox"/>	<input type="checkbox"/>	<input type="checkbox"/>
Safety Equipment			
External Debris Blower	<input type="checkbox"/>	<input type="checkbox"/>	<input type="checkbox"/>
Integrated Debris Blower	—	—	—
Road Lighting Kit	■	■	■
Warning Arrow Kit	<input type="checkbox"/>	<input type="checkbox"/>	<input type="checkbox"/>
Window Guards	—	—	—
Cab Protection Kit	■	■	■
Safety Breakaway	■	■	■
Power Slew	■	■	■
Cushioned Top Link	■	■	■
Tractor Requirements			
Minimum Tractor Weight	5,500kg	5,500kg	5,500kg
Minimum Tractor Horsepower	120hp	120hp	120hp
Specification			
Machine Weight #	TBC	1933kg	2291kg
Left and Right-Hand Build Options	<input type="checkbox"/>	<input type="checkbox"/>	<input type="checkbox"/>

* Including SoftStart ** Excluding axle brackets & latches # Depending on specification, excluding attachment & oil

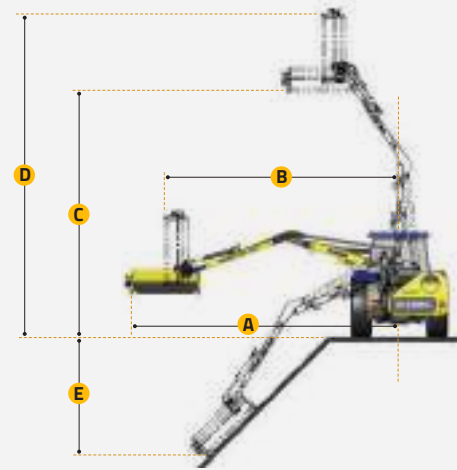

REACH DIMENSIONS

	PA6575T	PA7775T	PA8075T
A	6.6m / 21' 8"	7.75m / 25' 5"	8.0m / 26' 3"
B	6.0m / 19' 8"	7.15m / 23' 5"	7.4m / 24' 3"
C	5.9m / 19' 4"	7.03m / 23' 1"	7.4m / 24' 3"
D	7.4m / 24' 3"	8.52m / 27' 11"	8.8m / 28' 10"
E	3.1m / 10' 2"	3.94m / 12' 11"	4.1m / 13' 5"

POWER ARM FLAILHEADS

	PA6575T	PA7775T	PA8075T
1.00m Supercut Flailhead - DD	—	—	—
1.20m Supercut Flailhead - DD	—	—	—
1.20m Multicut Flailhead - DD	<input type="checkbox"/>	<input type="checkbox"/>	<input type="checkbox"/>
1.20m Multicut Flailhead - BD	<input type="checkbox"/>	<input type="checkbox"/>	<input type="checkbox"/>
1.20m Tuffcut Flailhead - DD	—	—	—
1.20m Twincut Flailhead - DD	<input type="checkbox"/>	—	—
1.20m Omega Flailhead - DD	<input type="checkbox"/>	<input type="checkbox"/>	<input type="checkbox"/>
1.20m Omega Flailhead - BD	<input type="checkbox"/>	<input type="checkbox"/>	<input type="checkbox"/>
1.50m Multicut Flailhead - DD	<input type="checkbox"/>	<input type="checkbox"/>	<input type="checkbox"/>
1.50m Multicut Flailhead - BD	<input type="checkbox"/>	<input type="checkbox"/>	<input type="checkbox"/>
1.50m Twincut Flailhead - DD	—	—	—
1.50m Omega Flailhead - DD	<input type="checkbox"/>	<input type="checkbox"/>	<input type="checkbox"/>
1.50m Omega Flailhead - BD	<input type="checkbox"/>	<input type="checkbox"/>	<input type="checkbox"/>
1.60m Multicut Flailhead - DD	—	—	—
1.60m Multicut Flailhead - BD	—	—	—
1.60m Tuffcut Flailhead - DD	—	—	—
1.60m Omega Flailhead - DD	—	—	—
1.60m Omega Flailhead - BD	—	—	—
2.00m Multicut Flailhead - DD	—	—	—
2.00m Multicut Flailhead - BD	—	—	—
Flailhead options			
Flailhead Skid Kit	<input type="checkbox"/>	<input type="checkbox"/>	<input type="checkbox"/>
Cushioned Grass Mowing Roller	<input type="checkbox"/>	<input type="checkbox"/>	<input type="checkbox"/>
Hydraulic Roller	<input type="checkbox"/>	<input type="checkbox"/>	<input type="checkbox"/>
Hydraulic Front Hood	<input type="checkbox"/>	<input type="checkbox"/>	<input type="checkbox"/>

■ Standard Equipment □ Optional Equipment — Not available

75 SERIES

A rugged heavy-duty series designed for full-time contractors, the 75 Series is precision-engineered from Domex Steel and features a radical new oil tank and cooling system for peak performance in all conditions.

Available in five different reach sizes from 5.6m to 8.0m and powered by high-performance 70hp hydraulics, the new series is available with a suite of advanced features including the REVOLUTION Control System, EDS, and the Tele-VFR armset.

- 5 Reach options from 5.6m to 8.0m
- 3 Advanced control options
- 4 Mounting options
- 2 Armset options
- 4 Floatation services
- 28 Attachment options





POWER ARM

77 SERIES

- PA5577-70** - 5.5m (18'1") reach
- PA6077-70** - 6.0m (19'8") reach
- PA6577VFR-70** - 6.5m (21'4") reach
- PA6577T-70** - 6.5m (21'4") reach
- PA7077T-70** - 7.0m (23'0") reach

77 SERIES

Advanced Controls	PA5577-70	PA6077-70	PA6577VFR-70	PA6577T-70	PA7077T-70
Cable Control	—	—	—	—	—
Motion Mini	—	—	—	—	—
Motion	☐	☐	☐	☐	☐
Evolution	☐	☐	☐	☐	☐
Revolution Including Easy Drive System (EDS)	☐	☐	☐	☐	☐
Two-way Rotor Engagement - Cable Control (CRC)	—	—	—	—	—
Two-way Rotor Engagement - Electric Control (ERC)*	■	■	■	■	■
Mounting					
Front 3-Point Mounting Including Stabiliser	—	—	—	—	—
Front DIN Plate Mounting	—	—	—	—	—
Rear 3-Point Mounting Including Stabiliser	■	■	■	■	■
Rear 3-Point to 4-Point Hitch Stabiliser Kit	☐	☐	☐	☐	☐
Rear 3-Point to 5-Point Axle Mounting Kit**	☐	☐	☐	☐	☐
Rear 5-Point Rigid Frame, Axle Mounting Kit**	—	—	—	—	—
Armsets					
Straight Armset	■	■	—	—	—
Midcut Armset	—	—	—	—	—
Telescopic Armset	—	—	—	■	■
Variable Forward Reach Armset (VFR)	☐	☐	■	—	—
Telescopic-Variable Forward Reach Armset (T-VFR)	—	—	—	—	—
Parallel Arm Geometry	■	■	■	■	■
Hydraulics					
Horsepower	70hp or 85hp	70hp or 85hp	70hp or 85hp	70hp or 85hp	70hp or 85hp
System Type	Gear	Gear	Gear	Gear	Gear
Pump Type	Cast	Cast	Cast	Cast	Cast
Total Flow Rate l/min	160.0	160.0	160.0	160.0	160.0
Arm Circuit Flow Rate l/min	32.0	32.0	32.0	32.0	32.0
Attachment Circuit Flow Rate l/min	128.0	128.0	128.0	128.0	128.0
Oil Tank Capacity	180ltrs	180ltrs	180ltrs	180ltrs	180ltrs
High Capacity Oil Cooler	■	■	■	■	■
Totally Independent Hydraulic System	■	■	■	■	■
Hydraulic Upgrades					
Angle Float Kit	☐	☐	☐	☐	☐
Lift Float Kit	☐	☐	☐	☐	☐
Advanced Float Kit (only on EVOLUTION controls)	☐	☐	☐	☐	☐
EDS (only on REVOLUTION controls)	☐	☐	☐	☐	☐
PowerBoost (75 l/min Arm Circuit Flow Rate)	—	—	—	—	—
Additional Hydraulic Services	☐	☐	☐	☐	☐
Safety Equipment					
External Debris Blower	—	—	—	—	—
Integrated Debris Blower	☐	☐	☐	☐	☐
Road Lighting Kit	■	■	■	■	■
Warning Arrow Kit	☐	☐	☐	☐	☐
Window Guards	■	■	■	■	■
Cab Protection Kit	☐	☐	☐	☐	☐
Safety Breakaway	■	■	■	■	■
Power Slew	■	■	■	■	■
Cushioned Top Link	■	■	■	■	■
Tractor Requirements					
Minimum Tractor Weight	4,000kg	4,000kg	5,500kg	4,500kg	5,000kg
Minimum Tractor Horsepower	100hp	100hp	100hp	100hp	100hp
Specification					
Machine Weight †	1233kg	1252kg	1463kg	1354kg	1375kg
Left and Right-Hand Build Options	☐	☐	☐	☐	☐

* Including SoftStart ** Excluding axle brackets & latches † Depending on specification, excluding attachment & oil

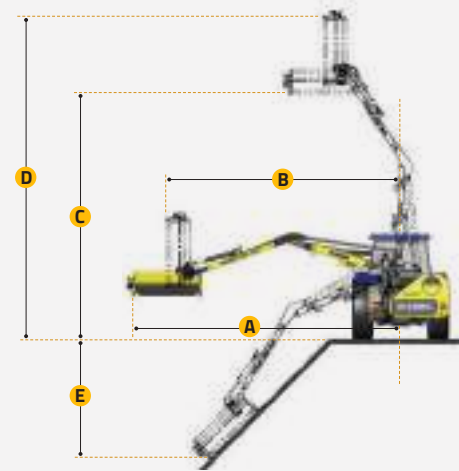

REACH DIMENSIONS

	PA5577-70	PA6077-70	PA6577VFR-70	PA6577T-70	PA7077T-70
A	5.5m / 18' 1"	6.0m / 19' 8"	6.5m / 21' 4"	6.5m / 21' 4"	7.0m / 23' 0"
B	4.9m / 16' 1"	5.4m / 17' 9"	5.9m / 19' 4"	5.9m / 19' 4"	6.4m / 21' 0"
C	5.1m / 16' 9"	5.6m / 18' 4"	6.2m / 20' 4"	6.0m / 19' 8"	6.5m / 21.4"
D	6.7m / 22' 0"	7.1m / 23' 4"	7.6m / 24' 11"	7.5m / 24' 7"	8.0m / 26' 3"
E	2.5m / 8' 2"	2.8m / 9' 2"	3.2m / 10' 6"	3.2m / 10' 6"	3.5m / 11' 6"

POWER ARM FLAILHEADS

	PA5577-70	PA6077-70	PA6577VFR-70	PA6577T-70	PA7077T-70
1.00m Supercut Flailhead - DD	—	—	—	—	—
1.20m Supercut Flailhead - DD	—	—	—	—	—
1.20m Multicut Flailhead - DD	☐	☐	☐	☐	☐
1.20m Multicut Flailhead - BD	☐	☐	☐	☐	☐
1.20m Tuffcut Flailhead - DD	☐	☐	☐	☐	☐
1.20m Tuffcut Flailhead - BD	☐	☐	☐	☐	☐
1.20m Twincut Flailhead - DD	☐	☐	—	—	—
1.20m Omega Flailhead - DD	☐	☐	☐	☐	☐
1.20m Omega Flailhead - BD	☐	☐	☐	☐	☐
1.50m Multicut Flailhead - DD	☐	☐	☐	☐	☐
1.50m Multicut Flailhead - BD	☐	☐	☐	☐	☐
1.50m Twincut Flailhead - DD	☐	☐	—	—	—
1.50m Omega Flailhead - DD	☐	☐	☐	☐	☐
1.50m Tuffcut Flailhead - DD	☐	☐	☐	☐	☐
1.50m Tuffcut Flailhead - BD	☐	☐	☐	☐	☐
1.50m Omega Flailhead - BD	☐	☐	☐	☐	☐
1.60m Multicut Flailhead - DD	☐	☐	—	—	—
1.60m Multicut Flailhead - BD	☐	☐	—	—	—
1.60m Tuffcut Flailhead - DD	☐	☐	☐	☐	☐
1.60m Tuffcut Flailhead - BD	☐	☐	☐	☐	☐
1.60m Omega Flailhead - DD	☐	☐	—	—	—
1.60m Omega Flailhead - BD	☐	☐	—	—	—
2.00m Multicut Flailhead - DD	—	—	—	—	—
2.00m Multicut Flailhead - BD	—	—	—	—	—

Flailhead	PA5577-70	PA6077-70	PA6577VFR-70	PA6577T-70	PA7077T-70
Flailhead Skid Kit	☐	☐	☐	☐	☐
Cushioned Grass Mowing Roller	☐	☐	☐	☐	☐
Hydraulic Roller	☐	☐	☐	☐	☐
Hydraulic Front Hood ###	☐	☐	☐	☐	☐

■ Standard Equipment ☐ Optional Equipment — Not available ### Excluding Twincut

77 SERIES

McConnell's 77-Series Power Arms are engineered for demanding applications by farmers, contractors, and local authorities. This heavy-duty series boasts a 70hp hydraulic system with reach options from 5.5m to 7.0m, including Telescopic and VFR options.

Enhanced features include larger pivot pins for increased durability, an optional 85hp hydraulic system, an integrated debris blower, LED road lighting, and improved service access. The 77-Series offers strong performance and versatility for the toughest vegetation management tasks.

- 4 Reach options from 5.5m to 7.0m
- 3 Advanced control options
- 3 Mounting options
- 5 Armset options
- 4 Flotation services
- 27 Attachment options



Larger Diameter Pivot Pins



POWER ARM

85 SERIES

PA6085 - 6.0m (19' 8") reach

PA6585 - 6.5m (21' 4") reach

85 SERIES

Advanced Controls	PA6085	PA6585
Cable Control	—	—
Motion Mini	—	—
Motion	<input type="checkbox"/>	<input type="checkbox"/>
Evolution	<input type="checkbox"/>	<input type="checkbox"/>
Revolution Including Easy Drive System (EDS)	<input type="checkbox"/>	<input type="checkbox"/>
Two-way Rotor Engagement - Cable Control (CRC)	—	—
Two-way Rotor Engagement - Electric Control (ERC)*	■	■
Mounting		
Front 3-Point Mounting Including Stabiliser	—	—
Front DIN Plate Mounting	—	—
Rear 3-Point Mounting Including Stabiliser	<input type="checkbox"/>	<input type="checkbox"/>
Rear 3-Point to 4-Point Hitch Stabiliser Kit	—	—
Rear 3-Point to 5-Point Axle Mounting Kit**	<input type="checkbox"/>	<input type="checkbox"/>
Rear 5-Point Rigid Frame, Axle Mounting Kit**	<input type="checkbox"/>	<input type="checkbox"/>
Armsets		
Straight Armset	<input type="checkbox"/>	<input type="checkbox"/>
Midcut Armset	—	—
Telescopic Armset	—	—
Variable Forward Reach Armset (VFR)	<input type="checkbox"/>	<input type="checkbox"/>
Telescopic-Variable Forward Reach Armset (T-VFR)	—	—
Parallel Arm Geometry	■	■
Hydraulics		
Horsepower	85hp	85hp
System Type	Gear	Gear
Pump Type	Cast	Cast
Total Flow Rate l/min	160.0	160.0
Arm Circuit Flow Rate l/min	32.0	32.0
Attachment Circuit Flow Rate l/min	128.0	128.0
Oil Tank Capacity	225ltrs	225ltrs
Oil Cooler	■	■
Totally Independent Hydraulic System	■	■
Hydraulic Upgrades		
Angle Float Kit	■	■
Lift Float Kit	<input type="checkbox"/>	<input type="checkbox"/>
Advanced Float Kit (only on EVOLUTION controls)	<input type="checkbox"/>	<input type="checkbox"/>
EDS (only on REVOLUTION controls)	<input type="checkbox"/>	<input type="checkbox"/>
PowerBoost (75 l/min Arm Circuit Flow Rate)	<input type="checkbox"/>	<input type="checkbox"/>
Additional Hydraulic Services	<input type="checkbox"/>	<input type="checkbox"/>
Safety Equipment		
External Debris Blower	—	—
Integrated Debris Blower	<input type="checkbox"/>	<input type="checkbox"/>
Road Lighting Kit	■	■
Warning Arrow Kit	<input type="checkbox"/>	<input type="checkbox"/>
Window Guards	■	■
Cab Protection Kit	■	■
Safety Breakaway	■	■
Power Slew	■	■
Cushioned Top Link	■	■
Tractor Requirements		
Minimum Tractor Weight	5,000kg	5,000kg
Minimum Tractor Horsepower	120hp	120hp
Specification		
Machine Weight #	1340kg	1500kg
Left and Right-Hand Build Options	<input type="checkbox"/>	<input type="checkbox"/>

* Including SoftStart ** Excluding axle brackets & latches # Depending on specification, excluding attachment & oil

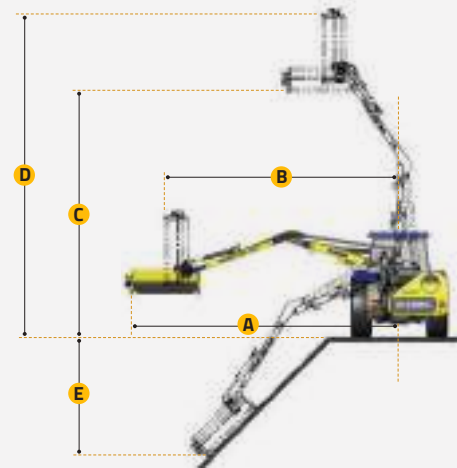

REACH DIMENSIONS

	PA6085	PA6585
A	6.0m / 19' 8"	6.5m / 21' 4"
B	5.4m / 17' 9"	5.9m / 19' 4"
C	5.6m / 18' 4"	5.7m / 18' 8"
D	7.0m / 22' 11"	7.1m / 23' 4"
E	2.8m / 9' 2"	3.0m / 9' 10"

POWER ARM FLAILHEADS

	PA6085	PA6585
1.00m Supercut Flailhead - DD	—	—
1.20m Supercut Flailhead - DD	—	—
1.20m Multicut Flailhead - DD	<input type="checkbox"/>	<input type="checkbox"/>
1.20m Multicut Flailhead - BD	<input type="checkbox"/>	<input type="checkbox"/>
1.20m Tuffcut Flailhead - DD	<input type="checkbox"/>	<input type="checkbox"/>
1.20m Twincut Flailhead - DD	<input type="checkbox"/>	<input type="checkbox"/>
1.20m Omega Flailhead - DD	<input type="checkbox"/>	<input type="checkbox"/>
1.20m Omega Flailhead - BD	<input type="checkbox"/>	<input type="checkbox"/>
1.50m Multicut Flailhead - DD	<input type="checkbox"/>	<input type="checkbox"/>
1.50m Multicut Flailhead - BD	<input type="checkbox"/>	<input type="checkbox"/>
1.50m Twincut Flailhead - DD	<input type="checkbox"/>	<input type="checkbox"/>
1.50m Omega Flailhead - DD	<input type="checkbox"/>	<input type="checkbox"/>
1.50m Omega Flailhead - BD	<input type="checkbox"/>	<input type="checkbox"/>
1.60m Multicut Flailhead - DD	<input type="checkbox"/>	<input type="checkbox"/>
1.60m Multicut Flailhead - BD	<input type="checkbox"/>	<input type="checkbox"/>
1.60m Tuffcut Flailhead - DD	<input type="checkbox"/>	<input type="checkbox"/>
1.60m Omega Flailhead - DD	<input type="checkbox"/>	<input type="checkbox"/>
1.60m Omega Flailhead - BD	<input type="checkbox"/>	<input type="checkbox"/>
2.00m Multicut Flailhead - DD	<input type="checkbox"/>	<input type="checkbox"/>
2.00m Multicut Flailhead - BD	<input type="checkbox"/>	<input type="checkbox"/>
Flailhead options		
Flailhead Skid Kit	<input type="checkbox"/>	<input type="checkbox"/>
Cushioned Grass Mowing Roller	<input type="checkbox"/>	<input type="checkbox"/>
Hydraulic Roller	<input type="checkbox"/>	<input type="checkbox"/>
Hydraulic Front Hood	<input type="checkbox"/>	<input type="checkbox"/>

■ Standard Equipment □ Optional Equipment — Not available

85 SERIES

Specifically designed for professional users, the 85-series delivers an exceptional performance and has been built to thrive on heavy workloads - making it ideal for large-scale farmers, professional contractors and highway verge-mowing teams.

85-series Power Arms are compatible with a comprehensive range of attachments, including Cutterbars, Rotary Heads, Multisaws, and Ditch and Grip Cleaners, - enhancing their functionality and enabling contractors to offer a broader range of green maintenance services.

- 6 Reach options from 6.0m to 9.0m
- 3 Advanced control options
- 3 Mounting options
- 4 Armset options
- 4 Floatation options
- 32 Attachment options





POWER ARM

85 SERIES

PA6585T - 6.5m (21' 4") reach

PA7085T - 7.0m (23' 0") reach

PA8085T - 8.0m (26' 3") reach

85 SERIES

Advanced Controls	PA6585T	PA7085T	PA8085T
Cable Control	—	—	—
Motion Mini	—	—	—
Motion	<input type="checkbox"/>	<input type="checkbox"/>	<input type="checkbox"/>
Evolution	<input type="checkbox"/>	<input type="checkbox"/>	<input type="checkbox"/>
Revolution Including Easy Drive System (EDS)	<input type="checkbox"/>	<input type="checkbox"/>	<input type="checkbox"/>
Two-way Rotor Engagement - Cable Control (CRC)	—	—	—
Two-way Rotor Engagement - Electric Control (ERC)*	■	■	■
Mounting			
Front 3-Point Mounting Including Stabiliser	—	—	—
Front DIN Plate Mounting	—	—	—
Rear 3-Point Mounting Including Stabiliser	—	—	—
Rear 3-Point to 4-Point Hitch Stabiliser Kit	—	—	—
Rear 3-Point to 5-Point Axle Mounting Kit**	—	—	—
Rear 5-Point Rigid Frame, Axle Mounting Kit**	■	■	■
Armsets			
Straight Armset	—	—	—
Midcut Armset	—	—	—
Telescopic Armset	■	■	■
Variable Forward Reach Armset (VFR)	—	—	—
Telescopic-Variable Forward Reach Armset (T-VFR)	—	—	—
Parallel Arm Geometry	■	■	■
Hydraulics			
Horsepower	85hp	85hp	85hp
System Type	Gear	Gear	Gear
Pump Type	Cast	Cast	Cast
Total Flow Rate l/min	160.0	160.0	160.0
Arm Circuit Flow Rate l/min	32.0	32.0	32.0
Attachment Circuit Flow Rate l/min	128.0	128.0	128.0
Oil Tank Capacity	225ltrs	225ltrs	225ltrs
Oil Cooler	■	■	■
Totally Independent Hydraulic System	■	■	■
Hydraulic Upgrades			
Angle Float Kit	■	■	■
Lift Float Kit	<input type="checkbox"/>	<input type="checkbox"/>	<input type="checkbox"/>
Advanced Float Kit (only on EVOLUTION controls)	<input type="checkbox"/>	<input type="checkbox"/>	<input type="checkbox"/>
EDS (only on REVOLUTION controls)	<input type="checkbox"/>	<input type="checkbox"/>	<input type="checkbox"/>
PowerBoost (75 l/min Arm Circuit Flow Rate)	<input type="checkbox"/>	<input type="checkbox"/>	<input type="checkbox"/>
Additional Hydraulic Services	<input type="checkbox"/>	<input type="checkbox"/>	<input type="checkbox"/>
Safety Equipment			
External Debris Blower	—	—	—
Integrated Debris Blower	<input type="checkbox"/>	<input type="checkbox"/>	<input type="checkbox"/>
Road Lighting Kit	■	■	■
Warning Arrow Kit	<input type="checkbox"/>	<input type="checkbox"/>	<input type="checkbox"/>
Window Guards	■	■	■
Cab Protection Kit	■	■	■
Safety Breakaway	■	■	■
Power Slew	■	■	■
Cushioned Top Link	■	■	■
Tractor Requirements			
Minimum Tractor Weight	5,500kg	5,500kg	5,500kg
Minimum Tractor Horsepower	120hp	120hp	120hp
Specification			
Machine Weight #	1650kg	1700kg	1800kg
Left and Right-Hand Build Options	<input type="checkbox"/>	<input type="checkbox"/>	<input type="checkbox"/>

* Including SoftStart ** Excluding axle brackets & latches # Depending on specification, excluding attachment & oil

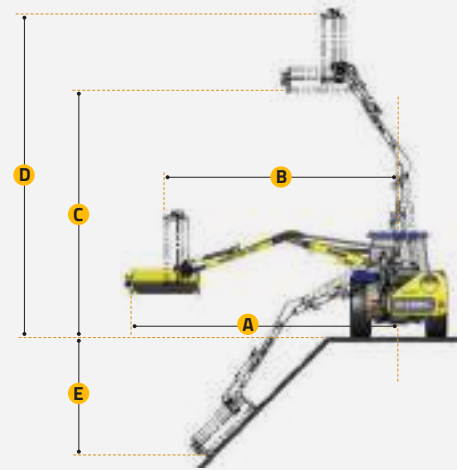

REACH DIMENSIONS

	PA6585T	PA7085T	PA8085T
A	6.5m / 21' 4"	7.0m / 23' 0"	8.0m / 26' 3"
B	5.9m / 19' 4"	6.4m / 21' 0"	7.4m / 24' 3"
C	5.7m / 18' 8"	6.1m / 20' 0"	7.4m / 24' 3"
D	7.1m / 23' 4"	7.5m / 24' 7"	8.8m / 28' 10"
E	3.0m / 9' 10"	3.4m / 11' 2"	4.1m / 13' 5"

POWER ARM FLAILHEADS

	PA6585T	PA7085T	PA8085T
1.00m Supercut Flailhead - DD	—	—	—
1.20m Supercut Flailhead - DD	—	—	—
1.20m Multicut Flailhead - DD	<input type="checkbox"/>	<input type="checkbox"/>	<input type="checkbox"/>
1.20m Multicut Flailhead - BD	<input type="checkbox"/>	<input type="checkbox"/>	<input type="checkbox"/>
1.20m Tuffcut Flailhead - DD	<input type="checkbox"/>	<input type="checkbox"/>	<input type="checkbox"/>
1.20m Twincut Flailhead - DD	—	—	—
1.20m Omega Flailhead - DD	<input type="checkbox"/>	<input type="checkbox"/>	<input type="checkbox"/>
1.20m Omega Flailhead - BD	<input type="checkbox"/>	<input type="checkbox"/>	<input type="checkbox"/>
1.50m Multicut Flailhead - DD	<input type="checkbox"/>	<input type="checkbox"/>	<input type="checkbox"/>
1.50m Multicut Flailhead - BD	<input type="checkbox"/>	<input type="checkbox"/>	<input type="checkbox"/>
1.50m Twincut Flailhead - DD	—	—	—
1.50m Omega Flailhead - DD	<input type="checkbox"/>	<input type="checkbox"/>	<input type="checkbox"/>
1.50m Omega Flailhead - BD	<input type="checkbox"/>	<input type="checkbox"/>	<input type="checkbox"/>
1.60m Multicut Flailhead - DD	—	—	—
1.60m Multicut Flailhead - BD	—	—	—
1.60m Tuffcut Flailhead - DD	—	—	—
1.60m Omega Flailhead - DD	—	—	—
1.60m Omega Flailhead - BD	—	—	—
2.00m Multicut Flailhead - DD	—	—	—
2.00m Multicut Flailhead - BD	—	—	—
Flailhead options			
Flailhead Skid Kit	<input type="checkbox"/>	<input type="checkbox"/>	<input type="checkbox"/>
Cushioned Grass Mowing Roller	<input type="checkbox"/>	<input type="checkbox"/>	<input type="checkbox"/>
Hydraulic Roller	<input type="checkbox"/>	<input type="checkbox"/>	<input type="checkbox"/>
Hydraulic Front Hood	<input type="checkbox"/>	<input type="checkbox"/>	<input type="checkbox"/>

■ Standard Equipment □ Optional Equipment — Not available

85 SERIES

Specifically designed for professional users, the 85-series delivers an exceptional performance and has been built to thrive on heavy workloads - making it ideal for large-scale farmers, professional contractors and highway verge-mowing teams.

85-series Power Arms are compatible with a comprehensive range of attachments, including Cutterbars, Rotary Heads, Multisaws, and Ditch and Grip Cleaners, - enhancing their functionality and enabling contractors to offer a broader range of green maintenance services.

- 6 Reach options from 6.0m to 9.0m
- 3 Advanced control options
- 3 Mounting options
- 4 Armset options
- 4 Floatation options
- 32 Attachment options





POWER ARM

85 SERIES

PA6585 TELE-VFR - 6.5m (21' 4") reach
PA7285 TELE-VFR - 7.2m (23' 7") reach
PA8085 TELE-VFR - 8.0m (26' 3") reach

85 SERIES

Advanced Controls	PA6585 T-VFR	PA7285 T-VFR	PA8085 T-VFR
Cable Control	—	—	—
Motion Mini	—	—	—
Motion	<input type="checkbox"/>	<input type="checkbox"/>	<input type="checkbox"/>
Evolution	<input type="checkbox"/>	<input type="checkbox"/>	<input type="checkbox"/>
Revolution Including Easy Drive System (EDS)	<input type="checkbox"/>	<input type="checkbox"/>	<input type="checkbox"/>
Two-way Rotor Engagement - Cable Control (CRC)	—	—	—
Two-way Rotor Engagement - Electric Control (ERC)*	■	■	■
Mounting			
Front 3-Point Mounting Including Stabiliser	—	—	—
Front DIN Plate Mounting	—	—	—
Rear 3-Point Mounting Including Stabiliser	—	—	—
Rear 3-Point to 4-Point Hitch Stabiliser Kit	—	—	—
Rear 3-Point to 5-Point Axle Mounting Kit**	—	—	—
Rear 5-Point Rigid Frame, Axle Mounting Kit**	■	■	■
Armsets			
Straight Armset	—	—	—
Midcut Armset	—	—	—
Telescopic Armset	—	—	—
Variable Forward Reach Armset (VFR)	—	—	—
Telescopic-Variable Forward Reach Armset (T-VFR)	■	■	■
Parallel Arm Geometry	■	■	■
Hydraulics			
Horsepower	85hp	85hp	85hp
System Type	Gear	Gear	Gear
Pump Type	Cast	Cast	Cast
Total Flow Rate l/min	160.0	160.0	160.0
Arm Circuit Flow Rate l/min	32.0	32.0	32.0
Attachment Circuit Flow Rate l/min	128.0	128.0	128.0
Oil Tank Capacity	225ltrs	225ltrs	225ltrs
Oil Cooler	■	■	■
Totally Independent Hydraulic System	■	■	■
Hydraulic Upgrades			
Angle Float Kit	■	■	■
Lift Float Kit	<input type="checkbox"/>	<input type="checkbox"/>	<input type="checkbox"/>
Advanced Float Kit (only on EVOLUTION controls)	<input type="checkbox"/>	<input type="checkbox"/>	<input type="checkbox"/>
EDS (only on REVOLUTION controls)	<input type="checkbox"/>	<input type="checkbox"/>	<input type="checkbox"/>
PowerBoost (75 l/min Arm Circuit Flow Rate)	<input type="checkbox"/>	<input type="checkbox"/>	<input type="checkbox"/>
Additional Hydraulic Services	<input type="checkbox"/>	<input type="checkbox"/>	<input type="checkbox"/>
Safety Equipment			
External Debris Blower	—	—	—
Integrated Debris Blower	<input type="checkbox"/>	<input type="checkbox"/>	<input type="checkbox"/>
Road Lighting Kit	■	■	■
Warning Arrow Kit	<input type="checkbox"/>	<input type="checkbox"/>	<input type="checkbox"/>
Window Guards	■	■	■
Cab Protection Kit	■	■	■
Safety Breakaway	■	■	■
Power Slew	■	■	■
Cushioned Top Link	■	■	■
Tractor Requirements			
Minimum Tractor Weight	5,500kg	6,000kg	6,000kg
Minimum Tractor Horsepower	120hp	140hp	140hp
Specification			
Machine Weight #	1950kg (TBC)	2004kg	2072kg
Left and Right-Hand Build Options	<input type="checkbox"/>	<input type="checkbox"/>	<input type="checkbox"/>

* Including SoftStart ** Excluding axle brackets & latches # Depending on specification, excluding attachment & oil

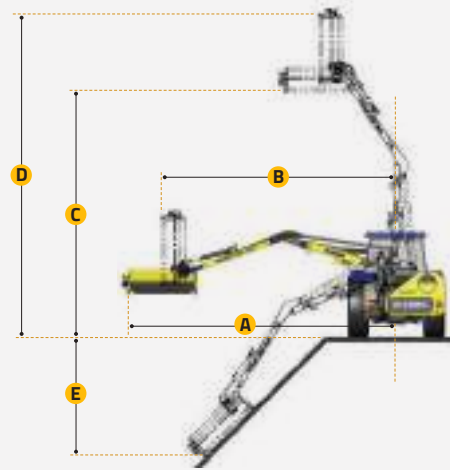

REACH DIMENSIONS

	PA6585 T-VFR	PA7285 T-VFR	PA8085 T-VFR
A	6.5m / 21' 4"	7.2m / 23' 7"	8.0m / 26' 3"
B	6.0m / 19' 8"	6.6m / 21' 8"	7.4m / 24' 2"
C	5.7m / 18' 8"	6.3m / 20' 8"	7.3m / 24' 0"
D	7.1m / 23' 3"	7.7m / 25' 3"	8.8m / 27' 2"
E	3.1m / 10' 2"	3.5m / 11' 6"	4.1m / 13' 5"

POWER ARM FLAILHEADS

	PA6585 T-VFR	PA7285 T-VFR	PA8085 T-VFR
1.00m Supercut Flailhead - DD	—	—	—
1.20m Supercut Flailhead - DD	—	—	—
1.20m Multicut Flailhead - DD	<input type="checkbox"/>	<input type="checkbox"/>	<input type="checkbox"/>
1.20m Multicut Flailhead - BD	<input type="checkbox"/>	<input type="checkbox"/>	<input type="checkbox"/>
1.20m Tuffcut Flailhead - DD	<input type="checkbox"/>	<input type="checkbox"/>	<input type="checkbox"/>
1.20m Twincut Flailhead - DD	—	—	—
1.20m Omega Flailhead - DD	<input type="checkbox"/>	<input type="checkbox"/>	<input type="checkbox"/>
1.20m Omega Flailhead - BD	<input type="checkbox"/>	<input type="checkbox"/>	<input type="checkbox"/>
1.50m Multicut Flailhead - DD	<input type="checkbox"/>	<input type="checkbox"/>	<input type="checkbox"/>
1.50m Multicut Flailhead - BD	<input type="checkbox"/>	<input type="checkbox"/>	<input type="checkbox"/>
1.50m Twincut Flailhead - DD	—	—	—
1.50m Omega Flailhead - DD	<input type="checkbox"/>	<input type="checkbox"/>	<input type="checkbox"/>
1.50m Omega Flailhead - BD	<input type="checkbox"/>	<input type="checkbox"/>	<input type="checkbox"/>
1.60m Multicut Flailhead - DD	—	—	—
1.60m Multicut Flailhead - BD	—	—	—
1.60m Tuffcut Flailhead - DD	—	—	—
1.60m Omega Flailhead - DD	—	—	—
1.60m Omega Flailhead - BD	—	—	—
2.00m Multicut Flailhead - DD	—	—	—
2.00m Multicut Flailhead - BD	—	—	—
Flailhead options			
Flailhead Skid Kit	<input type="checkbox"/>	<input type="checkbox"/>	<input type="checkbox"/>
Cushioned Grass Mowing Roller	<input type="checkbox"/>	<input type="checkbox"/>	<input type="checkbox"/>
Hydraulic Roller	<input type="checkbox"/>	<input type="checkbox"/>	<input type="checkbox"/>
Hydraulic Front Hood	<input type="checkbox"/>	<input type="checkbox"/>	<input type="checkbox"/>

■ Standard Equipment □ Optional Equipment — Not available

85 SERIES

Specifically designed for professional users, the 85-series delivers an exceptional performance and has been built to thrive on heavy workloads - making it ideal for large-scale farmers, professional contractors and highway verge-mowing teams.

85-series Power Arms are compatible with a comprehensive range of attachments, including Cutterbars, Rotary Heads, Multisaws, and Ditch and Grip Cleaners, - enhancing their functionality and enabling contractors to offer a broader range of green maintenance services.

- 6 Reach options from 6.0m to 9.0m
- 3 Advanced control options
- 3 Mounting options
- 4 Armset options
- 4 Floatation options
- 32 Attachment options





POWER ARM

85 SERIES

PA8085TT - 8.0m (26' 3") reach

PA9085TT - 9.0m (29' 6") reach

85 SERIES

Advanced Controls	PA8085TT	PA9085TT
Cable Control	—	—
Motion Mini	—	—
Motion	—	—
Evolution	—	—
Revolution Including Easy Drive System (EDS)	■	■
Two-way Rotor Engagement - Cable Control (CRC)	—	—
Two-way Rotor Engagement - Electric Control (ERC)*	■	■
Mounting		
Front 3-Point Mounting Including Stabiliser	—	—
Front DIN Plate Mounting	—	—
Rear 3-Point Mounting Including Stabiliser	—	—
Rear 3-Point to 4-Point Hitch Stabiliser Kit	—	—
Rear 3-Point to 5-Point Axle Mounting Kit**	—	—
Rear 5-Point Rigid Frame, Axle Mounting Kit**	■	■
Armsets		
Straight Armset	—	—
Midcut Armset	—	—
Telescopic Armset	■	■
Variable Forward Reach Armset (VFR)	—	—
Telescopic-Variable Forward Reach Armset (T-VFR)	—	—
Parallel Arm Geometry	—	—
Hydraulics		
Horsepower	85hp	85hp
System Type	Piston	Gear
Pump Type	Steel	Cast
Total Flow Rate l/min	156.0	203.0
Arm Circuit Flow Rate l/min	32.0	75.0
Attachment Circuit Flow Rate l/min	124.0	128.0
Oil Tank Capacity	225ltrs	225ltrs
Oil Cooler	■	■
Totally Independent Hydraulic System	■	■
Hydraulic Upgrades		
Angle Float Kit	■	■
Lift Float Kit	—	—
Advanced Float Kit (only on EVOLUTION controls)	—	—
EDS (only on REVOLUTION controls)	■	■
PowerBoost (75 l/min Arm Circuit Flow Rate)	□	■
Additional Hydraulic Services	□	□
Safety Equipment		
External Debris Blower	□	□
Integrated Debris Blower	—	—
Road Lighting Kit	■	■
Warning Arrow Kit	□	□
Window Guards	■	■
Cab Protection Kit	■	■
Safety Breakaway	■	■
Power Slew	■	■
Cushioned Top Link	■	■
Tractor Requirements		
Minimum Tractor Weight	6,000kg	7,000kg
Minimum Tractor Horsepower	140hp	150hp
Specification		
Machine Weight #	2072kg	2293kg
Left and Right-Hand Build Options	□	□

* Including SoftStart ** Excluding axle brackets & latches # Depending on specification, excluding attachment & oil

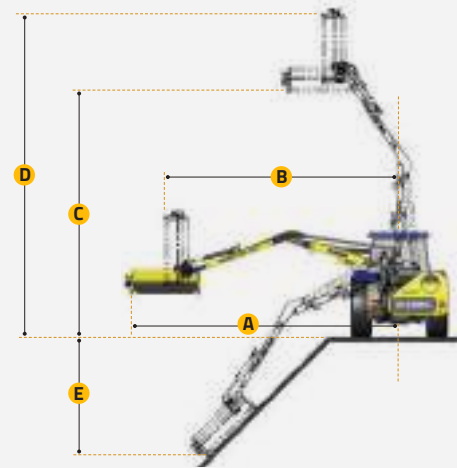

REACH DIMENSIONS

	PA8085TT	PA9085TT
A	8.0m / 26' 3"	9.0m / 29' 6"
B	7.4m / 24' 3"	8.9m / 29' 2"
C	7.0m / 23' 0"	7.6m / 24' 11"
D	8.0m / 26' 3"	8.6m / 28' 3"
E	4.1m / 13' 5"	4.8m / 15' 9"

POWER ARM FLAILHEADS

	PA8085TT	PA9085TT
1.00m Supercut Flailhead - DD	—	—
1.20m Supercut Flailhead - DD	—	—
1.20m Multicut Flailhead - DD	□	□
1.20m Multicut Flailhead - BD	□	□
1.20m Tuffcut Flailhead - DD	□	□
1.20m Twincut Flailhead - DD	—	—
1.20m Omega Flailhead - DD	□	□
1.20m Omega Flailhead - BD	□	□
1.50m Multicut Flailhead - DD	—	□
1.50m Multicut Flailhead - BD	□	□
1.50m Twincut Flailhead - DD	—	—
1.50m Omega Flailhead - DD	—	□
1.50m Omega Flailhead - BD	□	□
1.60m Multicut Flailhead - DD	□	—
1.60m Multicut Flailhead - BD	□	—
1.60m Tuffcut Flailhead - DD	□	—
1.60m Omega Flailhead - DD	□	—
1.60m Omega Flailhead - BD	□	—
2.00m Multicut Flailhead - DD	—	—
2.00m Multicut Flailhead - BD	—	—
Flailhead options		
Flailhead Skid Kit	□	□
Cushioned Grass Mowing Roller	□	□
Hydraulic Roller	□	□
Hydraulic Front Hood	□	□

■ Standard Equipment □ Optional Equipment — Not available

85 SERIES

Specifically designed for professional users, the 85-series delivers an exceptional performance and has been built to thrive on heavy workloads - making it ideal for large-scale farmers, professional contractors and highway verge-mowing teams.

85-series Power Arms are compatible with a comprehensive range of attachments, including Cutterbars, Rotary Heads, Multisaws, and Ditch and Grip Cleaners, - enhancing their functionality and enabling contractors to offer a broader range of green maintenance services.

- 6 Reach options from 6.0m to 9.0m
- 3 Advanced control options
- 3 Mounting options
- 4 Armset options
- 4 Floatation options
- 32 Attachment options





POWER ARM

VERSI SERIES

PA3430 VERSI - 3.4m (11' 2") reach

PA4030 VERSI - 4.0m (13' 1") reach

VERSI SERIES

Advanced Controls	PA3430 VERSI	PA4030 VERSI
Cable Control	—	—
Motion Mini	—	—
Motion	■	■
Evolution	—	—
Revolution Including Easy Drive System (EDS)	—	—
Two-way Rotor Engagement - Cable Control (CRC)	—	—
Two-way Rotor Engagement - Electric Control (ERC)*	■	■
Mounting		
Front 3-Point Mounting Including Stabiliser	■	■
Front DIN Plate Mounting	□	□
Rear 3-Point Mounting Including Stabiliser	—	—
Rear 3-Point to 4-Point Hitch Stabiliser Kit	—	—
Rear 3-Point to 5-Point Axle Mounting Kit**	—	—
Rear 5-Point Rigid Frame, Axle Mounting Kit**	—	—
Armsets		
Straight Armset	■	■
Midcut Armset	—	—
Telescopic Armset	—	—
Variable Forward Reach Armset (VFR)	—	—
Telescopic-Variable Forward Reach Armset (T-VFR)	—	—
Parallel Arm Geometry	—	—
Hydraulics		
Horsepower	30hp	30hp
System Type	—	—
Pump Type	—	—
Total Flow Rate l/min	55.0	55.0
Arm Circuit Flow Rate l/min	9.0	9.0
Attachment Circuit Flow Rate l/min	46.0	46.0
Oil Tank Capacity	—	—
Oil Cooler	—	—
Totally Independent Hydraulic System	—	—
Hydraulic Upgrades		
Angle Float Kit	□	□
Lift Float Kit	□	□
Advanced Float Kit (only on EVOLUTION controls)	—	—
EDS (only on REVOLUTION controls)	—	—
PowerBoost (75 l/min Arm Circuit Flow Rate)	—	—
Additional Hydraulic Services	□	□
Safety Equipment		
External Debris Blower	—	—
Integrated Debris Blower	—	—
Road Lighting Kit	—	—
Warning Arrow Kit	—	—
Window Guards	■	■
Cab Protection Kit	—	—
Safety Breakaway	■	■
Power Slew	■	■
Cushioned Top Link	—	—
Tractor Requirements		
Minimum Tractor Weight	1,750kg	2,000kg
Minimum Tractor Horsepower	35hp	55hp
Specification		
Machine Weight #	550kg	575kg
Left and Right-Hand Build Options	■	■

* Including SoftStart ** Excluding axle brackets & latches # Depending on specification, excluding attachment & oil

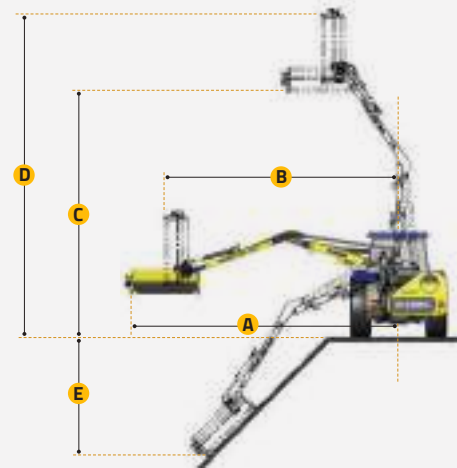

REACH DIMENSIONS

	PA3430 VERSI	PA4030 VERSI
A	3.4m / 11' 2"	4.0m / 13' 2"
B	3.1m / 10' 2"	3.9m / 12' 10"
C	3.0m / 9' 10"	3.6m / 11' 10"
D	3.9m / 12' 10"	4.5m / 14' 9"
E	1.1m / 3' 7"	1.7m / 5' 7"

POWER ARM FLAILHEADS

	PA3430 VERSI	PA4030 VERSI
1.00m Supercut Flailhead - DD	□	□
1.20m Supercut Flailhead - DD	□	□
1.20m Multicut Flailhead - DD	—	—
1.20m Multicut Flailhead - BD	—	—
1.20m Tuffcut Flailhead - DD	—	—
1.20m Twincut Flailhead - DD	—	—
1.20m Omega Flailhead - DD	—	—
1.20m Omega Flailhead - BD	—	—
1.50m Multicut Flailhead - DD	—	—
1.50m Multicut Flailhead - BD	—	—
1.50m Twincut Flailhead - DD	—	—
1.50m Omega Flailhead - DD	—	—
1.50m Omega Flailhead - BD	—	—
1.60m Multicut Flailhead - DD	—	—
1.60m Multicut Flailhead - BD	—	—
1.60m Tuffcut Flailhead - DD	—	—
1.60m Omega Flailhead - DD	—	—
1.60m Omega Flailhead - BD	—	—
2.00m Multicut Flailhead - DD	—	—
2.00m Multicut Flailhead - BD	—	—
Flailhead options		
Flailhead Skid Kit	□	□
Cushioned Grass Mowing Roller	—	—
Hydraulic Roller	—	—
Hydraulic Front Hood	—	—

■ Standard Equipment □ Optional Equipment — Not available

VERSI SERIES

Designed for specialist contractors working in the landscaping and amenities sectors, the PA3430 VERSI and PA4030 VERSI feature an innovative hydraulic side-shift that enables the operator to switch between left and right hand cutting at the touch of a button.

Front and rear mounting and a rotating flailhead, ensure these compact and manoeuvrable Power Arms offer operators the cutting flexibility to thrive in a wide variety of different work environments.

- 2 Reach options from 3.4m to 4.0m
- 2 Advanced control options
- 2 Mounting options
- Innovative armset
- 3 Floatation options
- 10 Attachment options





POWER ARM

VERSI SERIES

PA5565 VERSI - 5.5m (18' 1") reach

VERSI SERIES

Advanced Controls	PA5565 VERSI
Cable Control	—
Motion Mini	—
Motion	<input type="checkbox"/>
Evolution	<input type="checkbox"/>
Revolution Including Easy Drive System (EDS)	<input type="checkbox"/>
Two-way Rotor Engagement - Cable Control (CRC)	—
Two-way Rotor Engagement - Electric Control (ERC)*	■
Mounting	
Front 3-Point Mounting Including Stabiliser	—
Front DIN Plate Mounting	—
Rear 3-Point Mounting Including Stabiliser	■
Rear 3-Point to 4-Point Hitch Stabiliser Kit	—
Rear 3-Point to 5-Point Axle Mounting Kit**	<input type="checkbox"/>
Rear 5-Point Rigid Frame, Axle Mounting Kit**	—
Armsets	
Straight Armset	—
Midcut Armset	■
Telescopic Armset	—
Variable Forward Reach Armset (VFR)	—
Telescopic-Variable Forward Reach Armset (T-VFR)	—
Parallel Arm Geometry	■
Hydraulics	
Horsepower	65hp
System Type	Gear
Pump Type	Cast
Total Flow Rate l/min	—
Arm Circuit Flow Rate l/min	—
Attachment Circuit Flow Rate l/min	128.0
Oil Tank Capacity	110ltrs
Oil Cooler	■
Totally Independent Hydraulic System	■
Hydraulic Upgrades	
Angle Float Kit	<input type="checkbox"/>
Lift Float Kit	<input type="checkbox"/>
Advanced Float Kit (only on EVOLUTION controls)	<input type="checkbox"/>
EDS (only on REVOLUTION controls)	<input type="checkbox"/>
PowerBoost (75 l/min Arm Circuit Flow Rate)	—
Additional Hydraulic Services	<input type="checkbox"/>
Safety Equipment	
External Debris Blower	<input type="checkbox"/>
Integrated Debris Blower	—
Road Lighting Kit	■
Warning Arrow Kit	<input type="checkbox"/>
Window Guards	■
Cab Protection Kit	—
Safety Breakaway	■
Power Slew	■
Cushioned Top Link	■
Tractor Requirements	
Minimum Tractor Weight	4,500kg
Minimum Tractor Horsepower	100hp
Specification	
Machine Weight #	1750kg
Left and Right-Hand Build Options	■

* Including SoftStart ** Excluding axle brackets & latches # Depending on specification, excluding attachment & oil

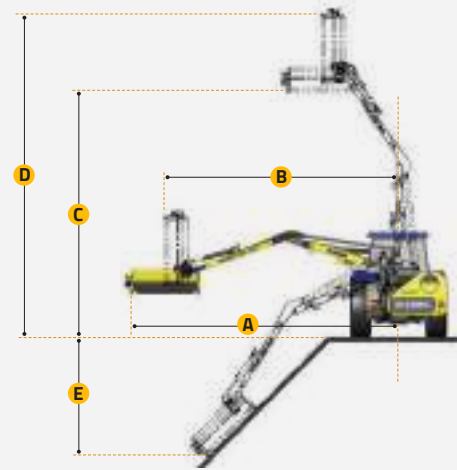

REACH DIMENSIONS

	PA5565 VERSI
A	5.5m / 18' 1"
B	5.0m / 16' 5"
C	5.6m / 18' 4"
D	6.8m / 22' 4"
E	4.5m / 14' 9"

POWER ARM FLAILHEADS

	PA5565 VERSI
1.00m Supercut Flailhead - DD	—
1.20m Supercut Flailhead - DD	—
1.20m Multicut Flailhead - DD	<input type="checkbox"/>
1.20m Multicut Flailhead - BD	<input type="checkbox"/>
1.20m Tuffcut Flailhead - DD	—
1.20m Twincut Flailhead - DD	—
1.20m Omega Flailhead - DD	<input type="checkbox"/>
1.20m Omega Flailhead - BD	<input type="checkbox"/>
1.50m Multicut Flailhead - DD	<input type="checkbox"/>
1.50m Multicut Flailhead - BD	<input type="checkbox"/>
1.50m Twincut Flailhead - DD	—
1.50m Omega Flailhead - DD	<input type="checkbox"/>
1.50m Omega Flailhead - BD	<input type="checkbox"/>
1.60m Multicut Flailhead - DD	—
1.60m Multicut Flailhead - BD	—
1.60m Tuffcut Flailhead - DD	—
1.60m Omega Flailhead - DD	—
1.60m Omega Flailhead - BD	—
2.00m Multicut Flailhead - DD	—
2.00m Multicut Flailhead - BD	—
Flailhead options	
Flailhead Skid Kit	<input type="checkbox"/>
Cushioned Grass Mowing Roller	<input type="checkbox"/>
Hydraulic Roller	<input type="checkbox"/>
Hydraulic Front Hood	—

■ Standard Equipment □ Optional Equipment — Not available

VERSI SERIES

Designed for specialists and professional contractors, the PA5565 VERSI has been created for highway mowing because it allows operators to safely cut both the nearside verge and the central reservation while travelling in the same direction as the traffic.

Featuring an innovative swing-around armset that enables operators to switch from right to left-hand cutting at the touch of a button, the PA5565 VERSI offers a generous 5.5m reach and high-performance 65hp hydraulics making it an essential tool for carriageway vegetation maintenance.

- 5.5m reach
- 3 Advanced control options
- 2 Mounting options
- Unique armset
- 4 Floatation options
- 18 Attachment options



Innovative Swing-around action



POWER ARM

BARRIER MOWER

MCCONNEL'S INNOVATIVE NEW
BARRIER MOWER

BARRIER MOWER

Mounting	
3-Point Linkage-Mounted (Cat II)	■
DIN Plate-Mounted	□
Tractor Requirements	
Minimum Tractor Weight	4500kg
Minimum Tractor Horsepower	85hp

■ Standard Equipment □ Optional Equipment

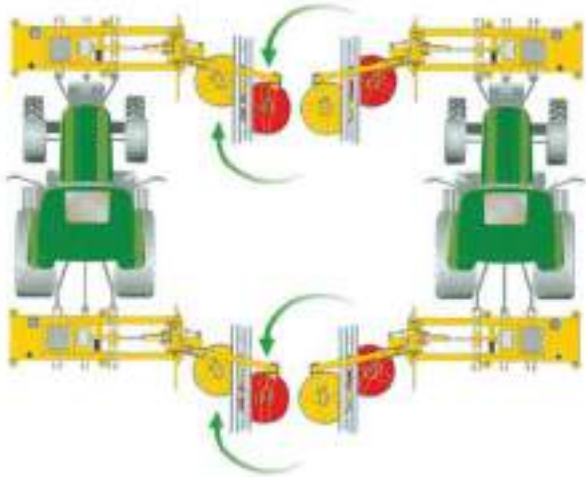

MACHINE SPECIFICATION

	BARRIER MOWER
Cutting Width	1.6m (5' 2")
Power Arm Horsepower	45hp
Machine Weight with Flailhead (exc. oil)*	1625kg
Oil Tank Capacity	170ltr

* depending on machine specification, excluding attachment and oil

BARRIER MOWER

Designed for cutting around roadside obstacles and guard rails, the Barrier Mower is an ideal tool for highway verge maintenance teams, specialist contractors, and local authorities.

The Barrier Mower's multi-position alignments and mounting options combine with a high-speed blade cutting system to ensure a fast and effective performance and an attractive finish.

Created to tackle the toughest challenges of carriageway grass maintenance, the McConnel Barrier Mower is one of the most effective and versatile machines on the market.

Featuring a high-position flex-arm and twin rotary cutting heads, the machine enables operators to cut quickly and safely around obstacles and armco barriers.

- Maximum working reach of 2.3m (to the centre of the barrier)
- Three point linkage mounting
- Front and rear mounting
- 1,000 rpm PTO
- High-capacity 170-litre oil tank
- 180-degree adjustable dipper arm
- Two cutting heads
- Left and right-hand cutting



Improves Visibility



Innovative Twin Rotary Head Design



FLAILHEADS & ROTORS

The flailhead is one of the most important parts of a Power Arm and McConnel can offer a comprehensive choice of models, working widths, rotors, flails and options so you can create the ideal specification to suit your needs.



McConnel's comprehensive selection of flailheads, flails, rotors and accessories, sets it apart from the competition and gives operators the opportunity to create a machine to a precise personal specification.

FLAILS

Six different flail types are available, including the patented F14 model that is unique to McConnel. Each flail is tough and durable and is designed to deliver an exceptional cutting performance.

(See pages 68-69)

FLAILHEADS

McConnel offer five different models and can supply everything from a 1.0m compact flailhead that's ideal for the Amenities market to a 2.0m behemoth designed for maximum productivity. (See pages 70-71)

OPTIONS AND ACCESSORIES

McConnel flailheads come with a full range of options and accessories to improve productivity and enhance durability. Operators can customise everything from hydraulic rollers to the position of the motor.

(See pages 72-73)

NEW F14 FLAIL

The first heavy-duty T-flail that's equally adept at verge mowing and hedgecutting. The F14 has earned rave reviews from operators for its durability, the superb finish it delivers and its ability to tackle mature hedgerows with ease.



NEW TUFFCUT FLAILHEAD

Created for professional contractors, the Tuffcut sets new standards for toughness and durability and features a lug design that's up to 65% stronger than its main rivals.



THE RANGE OF MCCONNEL POWER ARM FLAILS

McConnel's cutting-edge flail technology is unrivalled in the industry - delivering a range of high-performance flails which offer the widest choice, the greatest versatility and the best performance.

The all new F14 T-Flail



The launch of the new F14 T-Flail has seen McConnel make the most important breakthrough in flail design in more than a decade – creating the first heavy-duty flail that is equally adept at hedge-cutting and verge-mowing and can cut everything from fine wet grass to mature hedgerows.

A weight-saving patented cavity shaft and a series of innovative design refinements have also created a way to achieve exceptional heavy-duty cutting performance from a Power Arm without the need for a bigger, more powerful machine driving heavier flails.

Benefits of the F14 include:

- **CLEANER CUTTING**
Double the amount of flail overlap and improved cutting angle of the leading edge
- **IMPROVED CUTTING PERFORMANCE**
38% more mass for greater cutting momentum in tough conditions
- **INTEGRATED PROTECTION**
A durable pad protects flail and rotor when they come into contact
- **ANTI-WRAP PROFILE**
Rounded shank improves material flow preventing grass wrap
- **SUPERIOR VALUE**
Longer life and more applications at an affordable cost
- **STRONGER DESIGN**
A shank design that's stronger than conventional T-Flails
- **LONGER WORKING LIFE**
Longer leading edge profile extends service life
- **UNIQUE DESIGN**
Lighter cavity design compatible with all Multicut and Tuffcut rotors. Patent pending 1405860.6

With 6 specialist flails available, operators can specify their flailhead for the perfect cut and enjoy exceptional durability and an outstanding cutting performance.



BACK-TO-BACK GRASS FLAIL

Ideal for professional mowing duties, consists of two lightweight but hard wearing blades that leave a fine cut finish.

COMPATIBILITY

Supercut
Multicut
Tuffcut



UNI-BOOT FLAIL

Available in two different sizes and is ideal for annual hedge-trimming.

COMPATIBILITY

Supercut
Multicut
Tuffcut



COMPETITION J-FLAIL

A great all-rounder that's equally adept at both hedge-cutting and verge-mowing. Available in two models, medium-duty for the Supercut rotor and heavy-duty for the Multicut and Tuffcut rotor.

COMPATIBILITY

Supercut
Multicut
Tuffcut
Twincut (Rear Rotor only)



HEDGE T-FLAIL

Created for professional contractors. A tough heavy-duty flail that can withstand busy workloads. It features dual cutting edges for two-way cutting.

COMPATIBILITY

Supercut
Multicut
Tuffcut
Twincut (Front Rotor only)



F14 T-FLAIL

A dual-purpose heavy-duty T-flail that thrives on everything from long wet grass to hedgerows with three-year growth. It is extremely durable and delivers a neat attractive finish.

COMPATIBILITY

Multicut
Tuffcut
Twincut (1.2m Flailhead on Front Rotor only)



OMEGA FLAIL

Made from hardened steel with a double edged cutting surface for working in the toughest conditions.

COMPATIBILITY

Omega

THE RANGE OF MCCONNELL FLAILHEADS

Whatever the task, McConnell has developed a high-performance flailhead that can rise to the challenge and deliver an exceptional cutting performance.

From the compact, energy-efficient 1.0m Supercut flailhead to the innovative dual-rotor 1.5m Twincut, McConnell's advanced flailhead technology combines heavy-duty build quality, powerful rotors, cutting-edge design, and the widest selection of flails on the market.

A choice of 1.0m, 1.2m, 1.5m, 1.6m and 2.0m models are available as well as a wealth of customisation options and accessories – ensuring you can create the perfect cutting head for your needs.

FLAIL OPTION KEY

- A** Back-to-Back Grass Flail
- B** Uni-Boot Flail
- C** Competition J-Flail
- D** Hedge T-Flail
- E** F14 T-Flail
- F** Omega Flail

SUPERCUT FLAILHEAD

Ideally suited for agricultural and amenities machines, this flailhead is built around the Supercut rotor, which features weld-on lugs in a spiral layout for smooth reliable operation.

FLAILHEAD SIZES: 1.0m, 1.2m

SUPERCUT ROTOR



FLAIL OPTIONS

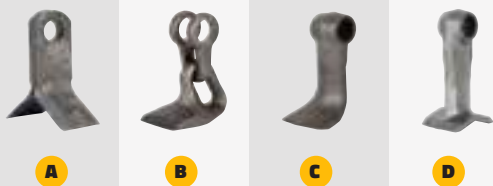

MULTICUT FLAILHEAD

Created for professional hedgecutting and verge mowing, this flailhead is built around the Multicut rotor and features wrap-around lugs which provide excellent strength and protection. The spiral layout ensures only two flails are cutting at a time for a smooth, continuous cutting action.

FLAILHEAD SIZES: 1.2m, 1.5m, 1.6m, 2.0m

MULTICUT ROTOR



FLAIL OPTIONS



TUFFCUT FLAILHEAD

Setting new standards for strength and durability, this flailhead has an innovative new lug design that's **65% stronger** and boasts a larger diameter rotor that's up to **75% stiffer**. Created for professional contractors, its captive bolt-head protects the bolt and prevents it from rotating – enhancing longevity.

FLAILHEAD SIZES: 1.2m, 1.6m

TUFFCUT ROTOR



FLAIL OPTIONS



OMEGA FLAILHEAD

McConel's most powerful flailhead has been created for professional green maintenance specialists tackling dense overgrowth and mature hedgerows. Its unique design allows heavy-duty flails to spin through 360 degrees - protecting the rotor from damage.

FLAILHEAD SIZES: 1.2m, 1.5m, 1.6m

OMEGA ROTOR



FLAIL OPTIONS



TWINCUT FLAILHEAD

Featuring not one but two high-powered Supercut rotors, the new Twincut Flailhead has been designed to tackle hedgerows in a single-pass - delivering both a heavy-duty cut and a fine finish in a single operation.

FLAILHEAD SIZES: 1.2m, 1.5m

2 X SUPERCUT ROTORS



FLAIL OPTIONS

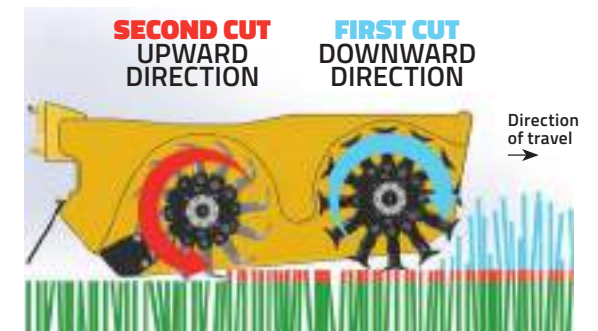
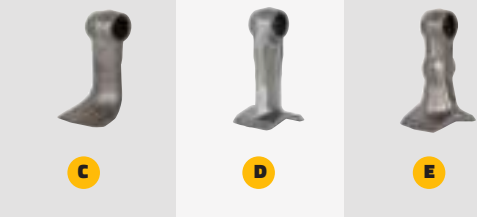

FLAILHEAD

OPTIONS AND ACCESSORIES

	SUPERCUT		MULTICUT				TUFFCUT		OMEGA			TWINCUT	
RANGE	Supercut-10	Supercut-12	Multicut-12	Multicut-15	Multicut-16	Multicut-20	Tuffcut-12	Tuffcut-16	Omega-12	Omega-15	Omega-16	Twincut-12	Twincut-15
Model Name	Supercut-10	Supercut-12	Multicut-12	Multicut-15	Multicut-16	Multicut-20	Tuffcut-12	Tuffcut-16	Omega-12	Omega-15	Omega-16	Twincut-12	Twincut-15
Cutting Width	1.0m	1.2m	1.2m	1.5m	1.6m	2.0m	1.2m	1.6m	1.2m	1.5m	1.6m	1.2m	1.5m
Horse Power Options	30hp	30hp, 45hp	54hp, 60hp, 65hp, 70hp, 75hp, 85hp	54hp, 60hp, 65hp, 70hp, 75hp, 85hp	54hp, 60hp, 65hp, 70hp, 75hp, 85hp	70hp, 75hp, 85hp	85hp	85hp	54hp, 60hp, 65hp, 70hp, 75hp, 85hp	65hp, 70hp, 75hp, 85hp	65hp, 70hp, 75hp, 85hp	65hp, 70hp, 75hp, 85hp	85hp
Rotor Type	Supercut	Supercut	Multicut	Multicut	Multicut	Multicut	Tuffcut	Tuffcut	Omega	Omega	Omega	2 x Supercut	2 x Supercut
Flail options													
Back-to-back Grass Flail	<input type="checkbox"/>	<input type="checkbox"/>	<input type="checkbox"/>	<input type="checkbox"/>	<input type="checkbox"/>	<input type="checkbox"/>	<input type="checkbox"/>	<input type="checkbox"/>	—	—	—	—	—
Uni-boot Flail	<input type="checkbox"/>	<input type="checkbox"/>	<input type="checkbox"/>	<input type="checkbox"/>	<input type="checkbox"/>	<input type="checkbox"/>	<input type="checkbox"/>	<input type="checkbox"/>	—	—	—	—	—
Competition J-Flail	<input type="checkbox"/>	<input type="checkbox"/>	<input type="checkbox"/>	<input type="checkbox"/>	<input type="checkbox"/>	<input type="checkbox"/>	<input type="checkbox"/>	<input type="checkbox"/>	—	—	—	<input checked="" type="checkbox"/> Rear Rotor	<input checked="" type="checkbox"/> Rear Rotor
Hedge T-Flail	<input type="checkbox"/>	<input type="checkbox"/>	<input type="checkbox"/>	<input type="checkbox"/>	<input type="checkbox"/>	<input type="checkbox"/>	<input type="checkbox"/>	<input type="checkbox"/>	—	—	—	<input checked="" type="checkbox"/> Front Rotor	<input checked="" type="checkbox"/> Front Rotor
F14 T-Flail	—	—	<input type="checkbox"/>	<input type="checkbox"/>	<input type="checkbox"/>	<input type="checkbox"/>	<input type="checkbox"/>	<input type="checkbox"/>	—	—	—	<input type="checkbox"/> Front Rotor	—
Omega Flail	—	—	—	—	—	—	—	—	<input checked="" type="checkbox"/>	<input checked="" type="checkbox"/>	<input checked="" type="checkbox"/>	—	—
Drive option													
Direct Drive	<input checked="" type="checkbox"/>	<input checked="" type="checkbox"/>	<input type="checkbox"/>	<input type="checkbox"/>	<input type="checkbox"/>	<input type="checkbox"/>	<input checked="" type="checkbox"/>	<input checked="" type="checkbox"/>	<input type="checkbox"/>	<input type="checkbox"/>	<input type="checkbox"/>	<input checked="" type="checkbox"/>	<input checked="" type="checkbox"/>
Belt Drive	—	—	<input type="checkbox"/>	<input type="checkbox"/>	<input type="checkbox"/>	<input type="checkbox"/>	—	—	<input type="checkbox"/>	<input type="checkbox"/>	<input type="checkbox"/>	—	—
Safety Equipment													
Front Flap Kit	<input checked="" type="checkbox"/>	<input checked="" type="checkbox"/>	<input checked="" type="checkbox"/>	<input checked="" type="checkbox"/>	<input checked="" type="checkbox"/>	<input checked="" type="checkbox"/>	<input checked="" type="checkbox"/>	<input checked="" type="checkbox"/>	<input checked="" type="checkbox"/>	<input checked="" type="checkbox"/>	<input checked="" type="checkbox"/>	—	—
Rear Flap Kit	<input checked="" type="checkbox"/>	<input checked="" type="checkbox"/>	<input checked="" type="checkbox"/>	<input checked="" type="checkbox"/>	<input checked="" type="checkbox"/>	<input checked="" type="checkbox"/>	<input checked="" type="checkbox"/>	<input checked="" type="checkbox"/>	<input checked="" type="checkbox"/>	<input checked="" type="checkbox"/>	<input checked="" type="checkbox"/>	<input checked="" type="checkbox"/>	<input checked="" type="checkbox"/>
Wire Trap	<input checked="" type="checkbox"/>	<input checked="" type="checkbox"/>	<input checked="" type="checkbox"/>	<input checked="" type="checkbox"/>	<input checked="" type="checkbox"/>	<input checked="" type="checkbox"/>	<input checked="" type="checkbox"/>	<input checked="" type="checkbox"/>	<input checked="" type="checkbox"/>	<input checked="" type="checkbox"/>	<input checked="" type="checkbox"/>	—	—
Adjustable Front Hood	<input checked="" type="checkbox"/>	<input checked="" type="checkbox"/>	<input checked="" type="checkbox"/>	<input checked="" type="checkbox"/>	<input checked="" type="checkbox"/>	<input checked="" type="checkbox"/>	<input checked="" type="checkbox"/>	<input checked="" type="checkbox"/>	<input checked="" type="checkbox"/>	<input checked="" type="checkbox"/>	<input checked="" type="checkbox"/>	—	—
Accessories & options:													
Skid Kit	<input type="checkbox"/>	<input type="checkbox"/>	<input type="checkbox"/>	<input type="checkbox"/>	<input type="checkbox"/>	<input type="checkbox"/>	<input type="checkbox"/>	<input type="checkbox"/>	<input type="checkbox"/>	<input type="checkbox"/>	<input type="checkbox"/>	—	—
Cushioned Roller	—	—	<input type="checkbox"/>	<input type="checkbox"/>	<input type="checkbox"/>	—	<input type="checkbox"/>	<input type="checkbox"/>	—	—	—	—	—
Hydraulic Roller	—	—	<input type="checkbox"/>	<input type="checkbox"/>	<input type="checkbox"/>	—	<input type="checkbox"/>	<input type="checkbox"/>	<input type="checkbox"/>	<input type="checkbox"/>	<input type="checkbox"/>	—	—
Hydraulic Front Hood	—	—	—	—	—	—	<input type="checkbox"/>	<input type="checkbox"/>	—	—	—	—	—
Weight													
Dependent on Specification	123kg	236kg	323kg	338kg	396kg	TBC	TBC	TBC	TBC	TBC	TBC	425kg	425kg

Standard Equipment
 Optional Equipment
 — Not available



SKID KITS

Protects the flailhead from wear and tear when verge-mowing and features a replaceable wear skid. Available on all types of flailhead, the kits reduce scalping and protect the flails, rotor and casing when closely following the contours of the ground.



DIRECT DRIVE

The hydraulic motor is incorporated into the side of the flailhead casing and directly drives the rotor shaft via a multi-spline drive coupling. The motor is protected by heavy-duty metal casing.



ADJUSTABLE FRONT HOOD

Fitted as standard on all flailheads, the height can be adjusted to suit specific jobs. Fully raised it allows large amounts of vegetation to enter the rotor, while the lowest position minimises the throwing of debris and ensures the mulch is retained within the hedgerow.



FRONT FLAP KITS

Available in standard and heavy-duty models, the kits improve safety by preventing material being thrown forward. The HD model features a rubber protection bar which protects the flailhead from damage from obstacles and also has Domex wear strips to extend its working life.



CUSHIONED ROLLER

Designed for verge-mowing professionals, the cushioned roller is available on the Multicut and Tuffcut flailheads. The larger diameter roller is covered in a thick layer of durable rubber absorbing shock and vibration, providing greater traction and reducing wear and tear on bearings.

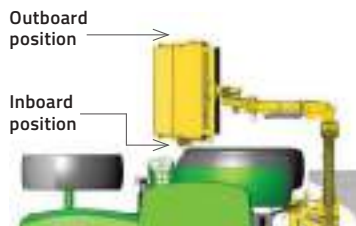

MOTOR LOCATION

Operators can specify the position of a flailhead drive motor to the inboard (tractor side) or outboard position to suit personal preference and application.



BELT DRIVE

Enables the hydraulic motor to be mounted within the flailhead width – reducing the overall profile, improving close-in cutting and protecting the motor from obstacles. Features a wide toothed Kevlar belt for long life and durability.



WIRE TRAP

Standard on all McConnel flailheads, the wire trap ensures any loose pieces of wire which are picked up and carried into the rotor are immediately cut so they fall to the ground, protecting the rotor and flails.



ADJUSTABLE ROLLER

Standard on all flailheads, the rear roller can be manually adjusted in six different positions, enabling operators to customise it to the task at hand. Benefits include reduced scalping, improved safety and greater protection for the flailhead.



HYDRAULIC ROLLER

An optional upgrade for the Multicut, Tuffcut and Omega flailheads, it enables operators to raise and lower the roller in and out of its working position quickly and easily from the cab. Perfect for switching between hedge-cutting and verge-mowing.

McConel has one of the most comprehensive ranges of Power Arm attachments available on the market today.



POWER ARM ATTACHMENTS

POWER ARM ATTACHMENTS

DITCH CLEANER

DITCH & GRIP **CLEANER**

The perfect tool for removing silt and mud from drainage ditches, this heavy-duty Power Arm attachment features four powerful cutting blades combined with four throwing blades for peak performance.

Technical specification

- 600mm (24") diameter rotary head
- Weight 323kg
- Four cutting blades
- Four throwing blades
- Choice of hydraulically operated 0-70 degree, or 0-120 degree head rotation
- Adjustable exit spout
- Heavy duty construction
- Choice of manual and hydraulic chute

SUITABILITY

55-series
60-series
65-series
67-series
70-series
75-series
85-series
65 VERSI-series



POWER ARM ATTACHMENTS

CUTTERBAR

McConel offers a choice of Cutterbars for a fine finish in a wide range of different working environments.

SWINGTRIM CUTTERBAR

Technical specification

- 1.2m or 1.5m working widths
- 20mm maximum cutting
- Minimum oil flow 12 ltrs/min
- Hard wearing teeth
- Easy to replace blades
- Weight: 40kg



SUITABILITY

Swingtrim

CUTTERBAR SD

MHL 150, MHL 180, MHL 210

Technical specification

- 1.5m, 1.8m and 2.1m working widths
- 30mm maximum cutting
- Minimum oil flow 20-40 ltrs/min @ 180bar
- 200-400 cuts per minute
- Hard wearing teeth
- Easy to replace blades
- Weight: 60-68kg



SUITABILITY

30-series
35-series
45-series
55-series
60-series
65-series
67-series
70-series
75-series
85-series

CUTTERBAR MD

MHS 200

Technical specification

- 2.0m working width
- 45mm maximum cutting
- Minimum oil flow
45 ltrs/min
- 60 cuts per minute
- Hard wearing teeth
- Easy to replace blades
- Weight: 130kg



SUITABILITY

45-series
55-series
60-series
65-series
67-series
70-series
75-series
85-series
Versi-series

CUTTERBAR HD

MHX 170, MHX 230, MHX 270

Technical specification

- 1.7m, 2.3m and 2.7m
working widths
- 110mm maximum cutting
- Minimum oil flow
45 ltrs/min
- 60 cuts per minute
- Hard wearing,
Hardox teeth
- Easy to replace blades
- Weight: 170-250kg



SUITABILITY

45-series*
55-series
60-series
65-series
67-series
70-series
75-series
85-series
Versi-series

*MHX 170 Only

POWER ARM ATTACHMENTS

MULTISAW

Made from high-tensile steel and armed with the bite of super-strength tungsten carbide teeth, McConel Multisaws deliver the perfect combination of a powerful cutting action and long-lasting durability.

MULTISAW HD 1500

Technical specification

- 1.5m working widths
- 150mm maximum cutting
- Minimum oil flow 124 ltrs/min @ 210bar
- 490mm blade diameter
- Hard wearing teeth
- Easy to replace blades
- Weight from 180kg

SUITABILITY

65-series
67-series
70-series
75-series
85-series



MULTISAW HD 2000

Technical specification

- 2.0m working width
- 150mm maximum cutting
- Minimum oil flow 124 ltrs/min @ 210bar
- 490mm blade diameter
- Hard wearing teeth
- Easy to replace blades
- Weight from 220kg

SUITABILITY

65-series
67-series
70-series
75-series
85-series



MULTISAW HD 2500

Technical specification

- 2.5m working width
- 200mm maximum cutting
- Minimum oil flow 124 ltrs/min @ 210bar
- 620mm blade diameter
- Hard wearing teeth
- Easy to replace blades
- Weight from 255kg

SUITABILITY

65-series
67-series
70-series
75-series
85-series



POWER ARM ATTACHMENTS

ROTARY HEAD

For those looking for an alternative robust cutting attachment, McConnell offers a range of five different rotary heads with a choice of working widths from 1.2m to 1.5m.

FINE CUT ROTARY HEAD

Technical specification

- 1.2m working width
- 25mm maximum cutting
- Minimum oil flow 45 ltrs/min
- Two rotors hydraulically driven
- Hard wearing blades
- Weight from 130kg

SUITABILITY

30-series
35-series
45-series
55-series
Versi-series



ROTARY HEAD MD/HD

Technical specification

- 1.2m and 1.5m working width
- 100mm maximum cutting
- Minimum oil flow from 100 ltrs/min
- Single rotor hydraulically driven
- Blade or chain option
- Weight from 260kg
- Deep pan option available

SUITABILITY

55-series
60-series
65-series
67-series
70-series
75-series
85-series
Versi-series



WHY MCCONNELL?

When you buy a McConnell rotary or flail mower, you're not just buying a high-performance machine – you're also getting a first-class aftercare package that supports you through the lifespan of your product. So whether you need an urgent part; service assistance; or online information on how to get the best from your machine, McConnell should always be your first choice.

Key benefits of buying your machine from McConnell include:

- An international network of dealers and distributors provides full service and support in 40 countries across the globe
- Every machine is subjected to an exhaustive performance test before being released to a customer
- A comprehensive stock of genuine replacement parts can be sent to dealers around the world via international couriers
- McConnell has a proud 80-year heritage and a proven track record of expertise in the design and manufacture of hedge-cutting and mowing technology
- From world's first to world's best – McConnell launched the first ever tractor mounted hedgecutter back in 1948 and has led the way as the number one in green maintenance ever since
- Our highly-skilled team of service professionals train hundreds of dealers every year and can offer expert support if you have an issue that can't be resolved quickly by your local dealer
- Customisation is fully supported with McConnell working with customers to help them create bespoke machines
- An online library of essential information including Operator's Guides, Parts Books, and multimedia product information is available 24/7

McConnel offers a proven product range, strong after-care support, and an international network of dealers and distributors spanning 40 countries, so if you're keen to take advantage of our high-performance products, **can you afford not to choose McConnel?**



REMOTE CONTROL

With four different models and a choice of 20 distinct working attachments, McConnel can offer a safe and effective remote control solution for almost any challenge. Featuring a 150m working range and an innovative low centre of gravity design, McConnel machines remove the operator from the danger zone and open up work environments that were previously hazardous, hard to reach or restricted-access.



For more information on McConnel's full machine line-up **please visit www.mcconnel.com**



FLAIL & ROTARY MOWERS

Whether you are looking for a flail or rotary mower, McConnel has a machine to match your needs with a choice of 12 different series and 27 machines available. The choice includes everything from 1.3m compact flail mowers through to an 8.2m high-performance flex-wing rotary mower.

AGRIBUGGY

Unrivalled low ground pressure design, market-leading traction and stability and greater comfort are just a few of the key benefits delivered by McConnel's Agribuggy2 AB30 power unit. The mechanical drive technology offers best-in-class traction - delivering power and braking to all four wheels simultaneously for better grip when working in wet conditions and tough terrain, allowing safe, productive working earlier and later in the year than rivals.

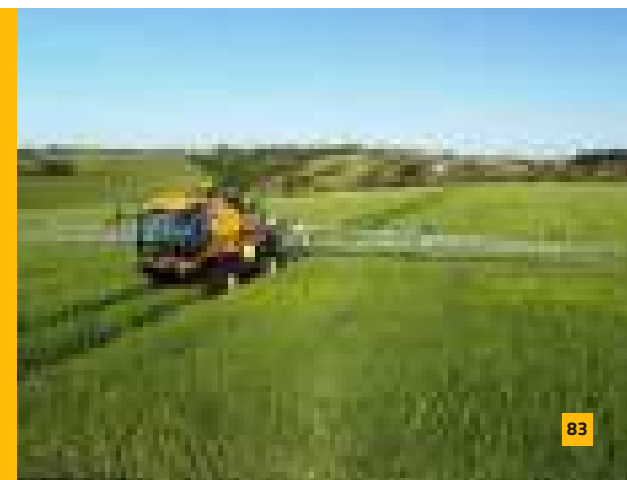

CONTACTS

McConnel Limited

Temeside Works, Ludlow, Shropshire SY8 1JL United Kingdom

Tel **+44 (0)1584 873131**

E-mail **sales@mcconnel.com**

Website **www.mcconnel.com**

Operations

SALES

Tel: +44 (0) 1584 873131
sales@mcconnel.com

PARTS

Tel: +44 (0) 1584 876888
parts@mcconnel.com

SERVICE

Tel: +44 (0) 1584 875848
service@mcconnel.com

MARKETING

Tel: +44 (0) 1584 813412
marketing@mcconnel.com



SALES

Tel: +44 (0)1584 873131
sales@mccannel.com

PARTS

Tel: +44 (0)1584 876888
parts@mccannel.com

SERVICE

Tel: +44 (0)1584 875848
service@mccannel.com

MARKETING

Tel: +44 (0)1584 813412
marketing@mccannel.com



McConnel Limited
Temeside Works, Ludlow,
Shropshire SY8 1JL
United Kingdom

Tel **+44 (0)1584 873131**
E-mail **sales@mccannel.com**
Website **www.mccannel.com**



100% Recyclable
Responsibly
sourced paper



FM 25970

A Member of the



POWNER

TECHNOLOGY

2024