



A perfect match!

Successful milking with GEA liners



TO MILK YOUR HERD SUCCESSFULLY,
YOU NEED LINERS THAT SUIT BOTH YOUR MILKING
UNITS AND ANIMALS. SIZE, MATERIAL AND BARREL
SHAPE ALL PLAY A CRUCIAL ROLE ...

Contents

The right choice makes the difference!	04
Milking with GEA: four good reasons to choose GEA liners	07
All liners are the same? A costly mistake to make ...	10
The heart of your milking system ...	10
First things first: size matters!	12
Material selection: silicone or rubber	13
Liner barrel shapes – it's what's inside that counts	15
Liners for GEA claws and AMS	16
Liners for Classic claws	16
Liners for the IQ claw	18
Liners for the ApolloMilkSystem	20
Liners for GEA automated milking systems (AMS)	22
Simple and efficient: in 10 steps to a good milking routine	24
Better to be safe than sorry: always keep an eye on replacement intervals	26
Overview of the GEA liners	28

The right choice makes the difference!

Independent from herd size most farmers have two main questions. How can I make my daily milk production process as reliable, cost-effective and animal-friendly as possible? And what do I need to optimise to do so?

This is where the liners come into play: they are crucial to achieving optimal milking results. Why? Liners are the only component that connect the cow to the milking unit. Their role is similar to that of your car's tyres. To achieve maximum performance, safety and efficiency every time you drive, the size and material properties have to fit the model perfectly. The same goes for liners. Unfortunately, there's no such thing as one-size-fits-all solution. The reason: genetic efforts has led to changes in the shapes and sizes of their teats and udders, and there can be considerable variations within a single herd. In short: you need the right liner!

More than 30 liners – designed with farmers, for farmers

Is it possible to ideally milkout cows and maintain good udder health at the same time? With the right liner it is. GEA's product research and development team have worked closely with dairies all over the world for more than 100 years. The result: milking systems with components designed precisely to your needs. Like the GEA liner range, which has more than 30 rubber and silicone models to choose from. All quality controlled and certified to the latest standards. The broad range of sizes and barrel shapes is designed to ensure that you can always find the perfect solution to your needs – even across multiple generations of cows.

Milking a cow until the last drop of milk?

Not a good idea ...

A milk-out at all costs is definitely not the best idea if you're looking for a sustainable milking process. You are far better off developing a holistic milking philosophy that ensures long-term success with high yields and healthy cows. It saves you time, money and hassle.

The four pillars of optimal cow milking with GEA

- Safe milking for cows and staff
- Gentle milking to maintain optimum teat and udder health
- Efficient milking for excellent time management
- Ideal milk-out for maximum yields

Don't leave it up to chance:

here's how to find your perfect liner

Which liner fits which milking unit? Is silicone better than rubber? Square or round? It can be rather difficult to make the right decisions. So if you want to be absolutely sure, our GEA system partners are more than happy to provide personal advice on-site. GEA's worldwide dealer and service network is available around the clock.

Dairy Farming Dealers

gea.com/find-your-dealer



Liners consist of three main components:

- Mouthpiece
- Barrel
- Short milk hoses

The performance of a liner is determined by four key factors:

- Barrel diameter and size
- Material: silicone or rubber
- Barrel shape
- Mouthpiece geometry

The teat cup is an assembly consisting of a shell and a liner and is equipped with a short pulse tube and short milk hose.

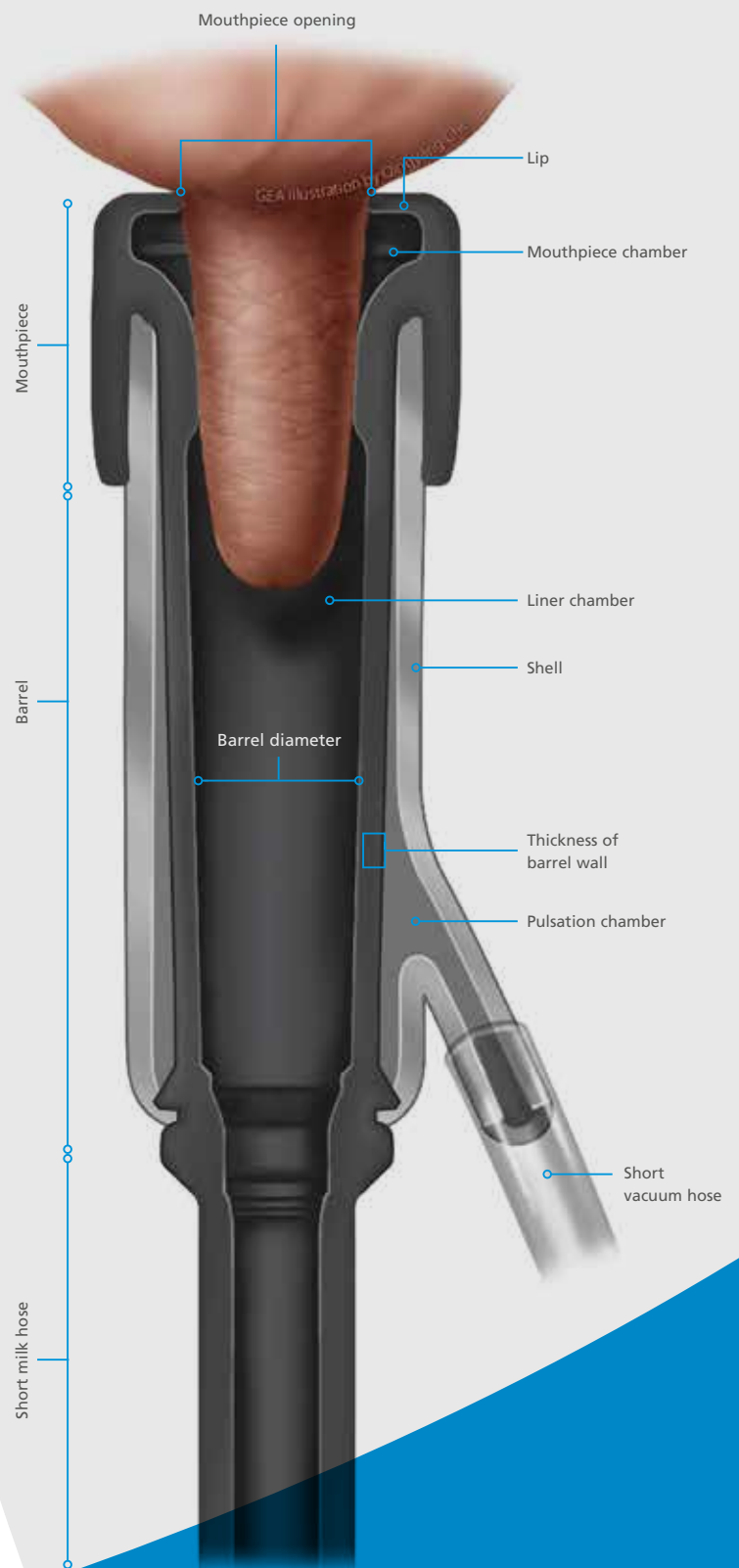

LINERS – TRUE PERFORMANCE ATHLETES

GEA liners are true performance athletes: Over a working life of 1,500 hours, a silicone liner will open and close more than 5 million times to secure the milk flow. Original GEA liners guarantee optimum milking performance over their entire lifespan, whilst also keeping your animals as healthy as possible.



You can only achieve the best milking performance for your farm and animals when the four pillars for optimal cow milking are perfectly aligned with one another. The milking experts in GEA's global dealer and service network are happy to support you at every stage – around the clock, 365 days a year.

Milking with GEA: four good reasons to choose GEA liners

How do you benefit from a GEA liner? It's simple really: the experience, knowledge and requirements of dairy farms around the world have always been the foundation and driving force behind our product developments – made with farmers, for farmers.

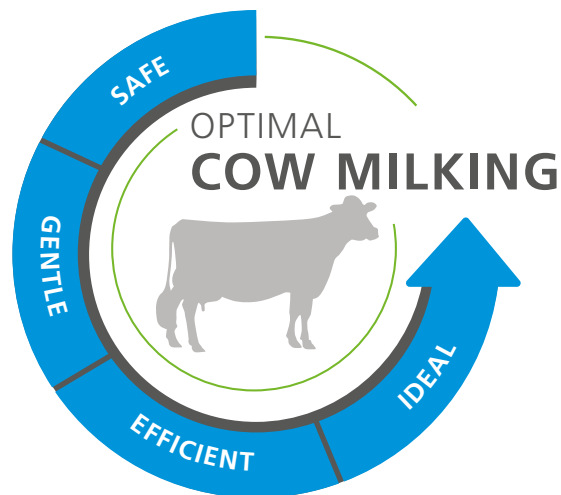

We follow a simple philosophy: to create milking solutions supporting cost and health effective milk harvest of your cows.

Optimal cow milking – no easy task ...

Successful milking is a complex process that has to take many different factors into account. As well as vacuum and pulsation settings, the right choice of liner is also incredibly important. It's not a place to make compromises. And with a range of more than 30 liners to choose from, with us, you don't have to. At every stage from the initial development of the GEA liners to installing them at your farm, we always focus on four objectives optimal cow milking:

- Safe milking
- Gentle milking
- Efficient milking
- Ideal milk-out

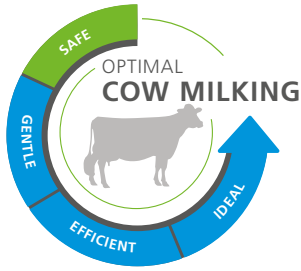

Safe milking ...

Safe milking starts with a comfortable milking environment that reduces both the risk of injury, especially to the udders and teats, and stress for the milkers and animals. The quality of the liner is a key factor here. And, as with all GEA products, you can rely on us.

Certified food safe material

All silicone and rubber GEA liners are certified to current national food safety standards.

Continuous quality checks and traceability

GEA's liner production process is monitored with continuous quality checks. Parameters such as the liners' geometric shape, tear-resistance and touch point pressure differences are tested to the latest industry standards.

Long-term field tests before release

All liners have to undergo comprehensive long-term testing at hard-working dairy farms around the world before being approved for use in GEA milking systems. The result: liners stay securely attached throughout the entire milking process, prevent air slips, pathogen infiltration and injuries to the teat and udder tissue, and boost your herd's milking performance.

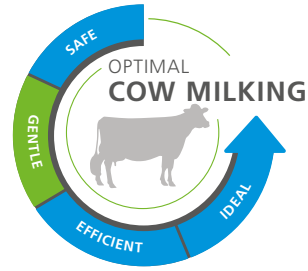

Gentle milking ...

In a gentle milking process, every individual cow is milked calmly and stress-free. In order to achieve optimal results at every milking, it is vital to ensure that the cows find the process comfortable, and that their teats and udders stay healthy.

To do this, the milking processes and routines and the GEA milking unit and liner have to be configured to ensure maximum comfort. If a cow is not at ease during the milking process or kicks out, this is a clear sign that something is not right. It may be that a poorly selected liner is uncomfortable on the cow's teats or does not adhere properly. The consequence: the effect of the milk let-down hormone oxytocin may be impeded, the cows show discomfort and the milk flow may in turn become restricted or even stop completely.

The size, material and shape of the liner are critical

GEA's wide range of liners in a variety of different sizes, materials and shapes offer tailored solutions for all of the teats and udders in your herd. So you can milk them gently and help to keep your cows healthy and performing at their best.

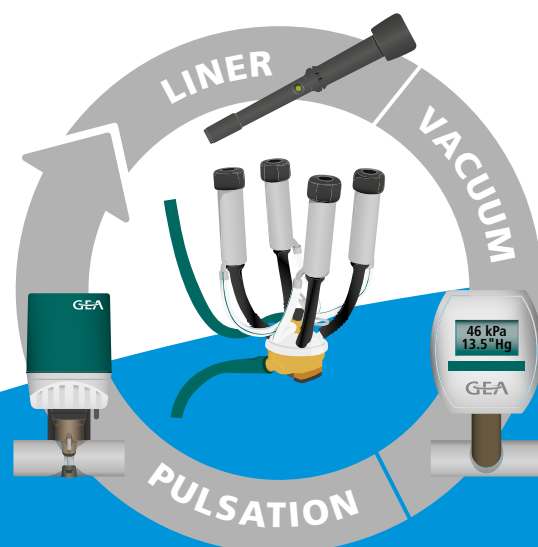

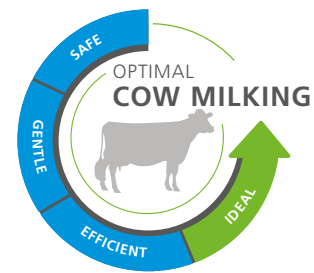
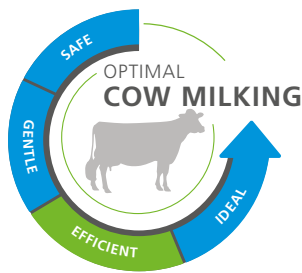

Efficient milking ...

You cannot milk a cow efficiently and gently without slowing down the process. It's something we hear a lot, but the two are not necessarily mutually exclusive – if you take a systematic approach that looks at the big picture. We call this efficient milking.

Milking time is greatly influenced by the milking system used and its operating parameters. The milking processes and routines, the number of trained, experienced milkers and the make-up of the herd also play an important role.

How you can make milking efficient

The main requirement for efficient milking is well-maintained, perfectly-functioning milking equipment from GEA. Equally important: the right milking parameter configurations and how they align with one another. One factor to be particularly aware of is whether the vacuum settings and pulsation values lie within the recommended ranges. The GEA liners you choose must also meet the herd's needs in terms of size, material and shape in order to ensure a smooth, gentle milking process for the animals. The design of all GEA silicone and rubber liners has been continuously optimised from the initial idea stage, through testing and on to standard release to ensure that it provides an additional, performance-enhancing stimulation effect and therefore increases milking success. If all of the components and parameters work well together, you can ensure you achieve your personal goals over the long term, saving time and money by milking efficiently.

Ideal milk-out ...

The amount of milk harvested from each cow at every milking session influences performance and herd health. And therefore the profitability of your dairy farm. Ensuring the animals are milked out ideal is the key to your success.

In practice, we still often hear that “milking cows out to the very last drop means more milk”. But this is not actually the case, because milking an animal dry does not increase milk yields, and can in fact be detrimental to udder health. You are much better off ensuring that the udder is perfectly milked out but also protected, as this will help you achieve stable, high milk yields across the entire lactation stage.

Ideal for milking: good adhesion with tailored geometry

Even if you are milking your animals out perfectly, you also need to configure and align the components and parameters of your GEA milking system correctly – particularly the liners, pulsation and detachment settings – to guarantee the success of the milking process. This is why GEA's range of liners offers a variety of different designs and sizes that provide excellent adhesion and stimulation during milking, and are also gentle on the teats supporting an ideal milk-out.

YOUR BENEFITS – THE BOTTOM LINE ...

Aligning the combination of cows, GEA technology, liners and herd management optimally, you can open up options that will help you continue to optimise the potential of your dairy farm over the long term. With quality and economic advantages that everyone can benefit from: your cows, your company, your staff, and of course, your customers.

All liners are the same? A costly mistake to make ...

Having things fit with a bit of wiggle-room might work for many hobby craftsmen, but not for a professional milker like you. Because if you start to hear a air leakage during milking, it's the sound of a code red.

This can mean that the wrong liners are being used. They do not or no longer suit the teats and therefore cause attachment issues. The consequence: air leakage– which you hear as a slurping sound from the milking unit. It's a mistake that has expensive consequences for farmers and their animals: ineffective milk-out with lower milk yields, stressed cows and poor udder health. But choosing the right liner is not rocket science. The base is the milking claw you use or plan to use in future.

When choosing liners for the milking claw, simply follow this formula:

size + material + barrel shape.

Because one size does not fit all ...

»» PAGES 12 – 15

The heart of your milking system ...

You can compare the role of the milking claw in your milking unit to that of the heart: a strong muscle, collecting the milk and transferring it to where it's needed. Its performance determines milking success. But it has to work in tandem with the right liner. This is the only way that the milking units work efficiently and gently on your animals. You need to find the perfect combination ...

Fine-tuned to your farm's needs

One of the most important parts of your parlour will always be the milking unit. Which makes it all the more crucial to choose a milking unit that perfectly matches your milking strategy and

herd in terms of functionality, performance and efficiency. And to fit it with a range of liners that suit the milking claw so that you can fine-tune the milking performance to the udder conditions within your herd.

Finding the right match ...

Whether you have a small herd with average milk yields or run a large dairy full of high-performance animals, you can always find the right silicone and rubber liners for your GEA milking units in our range – user-friendly, powerful, long-lasting and comfortable for the cows.



LINERS FOR THE CLASSIC CLAWS

Single- or multi-part, round or non-round – the ever-popular GEA all-rounder system comes with our largest range of silicone and rubber liners.

»» **PAGE 16**



LINERS FOR THE IQ CLAW

We offer an exclusive selection of silicone and rubber liners for the revolutionary 4-way GEA IQ technology.

»» **PAGE 18**



LINERS FOR THE APOLLOMILKSYSTEM

The rubber ApolloIQLiner is designed for milking in conventional parlours with an automated dip process and disinfection cycle.

»» **PAGE 20**



LINERS FOR AUTOMATED MILKING SYSTEMS (AMS)

The all-rounder for automated milking: the entire process, including preparation, takes place inside the liner.

»» **PAGE 22**



First things first: size matters!

When it comes to choosing the right liner, you have to do things in the right order. Start with the most important thing first – and here, that means choosing the right size.

The length and diameter have to suit the teats of your herd. They should fit like a glove: not too tight, not too loose, not too short and not too long. What might fit a Holstein-Friesian perfectly could be completely unsuitable for a Fleckvieh cow. This could then result in poor adhesion and massage stimulation, transfer of mastitis pathogens, hyperkeratosis, teat cups cratering or complete fall-offs of milking units.

No off-the-rack solutions ...

Every farm is different – so is milking. A standard, off-the-rack solution is normally just a compromise. But what do you get from us? More than 30 different types of liners – developed in line with the individual requirements and needs of experienced professionals like you. So you can be sure that your GEA milking unit always provides the best performance. Whether you have been working with a Classic claw for years or have just installed the latest generation of GEA automated milking systems (AMS).

Material selection: silicone or rubber

Once you have decided which size you need, you can move on to softer factors about the liner: whether to go for a silicone or rubber option.

GEA carries out comprehensive field and quality tests on both materials before they are approved for use on farms. As well as high mechanical durability, the liners also have to be resistant to influences like butterfat absorption and chemicals such as detergents and disinfectants. This means that you can rely on that both materials can ensure high-quality, hygienic, and smooth milking processes at your farm.

Middle distance or marathon runners?

The main area in which silicone and rubber liners differ is their lifespan. While a rubber liner is a good middle distance performer with a lifespan of 750 hours (2,500 milkings), a silicone liner lasts 1,500 hours (5,000 milkings), making it more of a marathon runner. Dairy farmers with large herds in particular prefer these as they lengthen the intervals between time- and cost-intensive replacements.



THE MOST IMPORTANT FEATURES AT A GLANCE

	Silicone liners	Rubber liners
Lifespan	++ 1,500 hours 5,000 milkings	+ 750 hours 2,500 milkings
Elasticity and softness	++ <i>Adapts well to the teat: gentle, effective and constant massage and milking throughout its lifetime</i>	+
Cow health	++ <i>Liner surface remains free from tears over the long term: minimises the risk of pathogens growing on the surface</i>	+
Environmental influences	++ <i>Insensitive to environmental influences, e.g. temperature, ozone and chemicals</i>	+
Mechanical overstress	+ <i>Liner mouthpiece is protected from damage with integrated shock absorbers rather than traditional protective devices such as a plastic fringe</i>	++ <i>More resistant to, for example, scratches from sharp housing edges or hooves</i>
Cleaning management	+	++ <i>Appropriate cleaning routines are essential for any liner, regardless of the material. Silicone, for example, is less sensitive to detergents and disinfectants, but has higher requirements with regard to process parameters, e.g. water temperature</i>

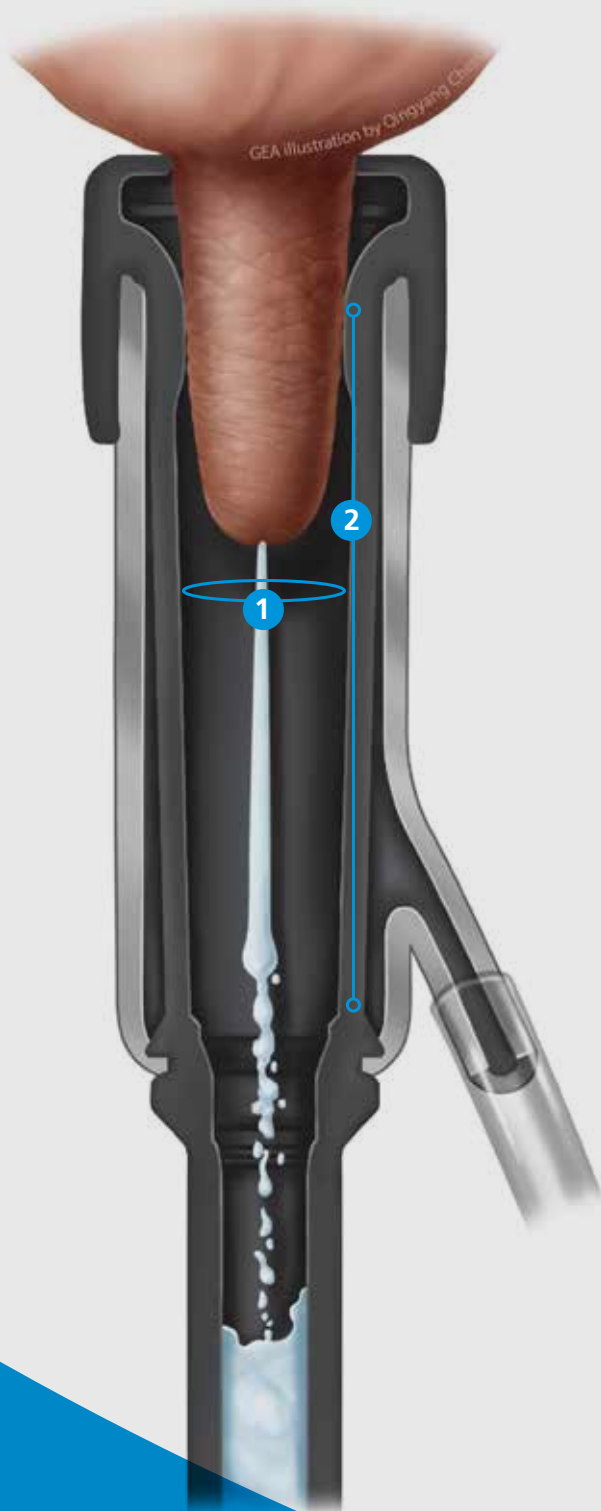

1 Different barrel shapes collapse in different ways. Aerial view of round, triangular and square barrels in their open and closed positions:

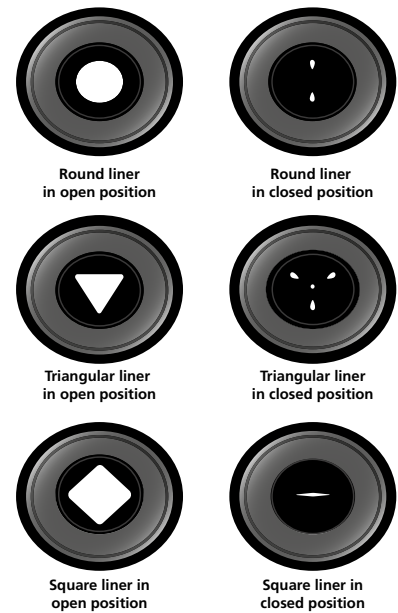

GQ liner – unique design feature: 4 rounded openings in the barrel that are not connected to the liner mouthpiece prevent a high head vacuum – without any additional components such as ventilation openings on the mouthpiece itself.



2 The liner barrels can be cylindrical or conical:

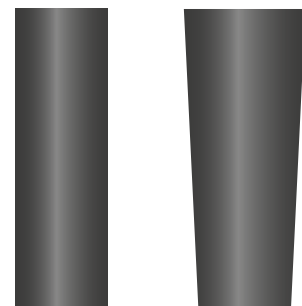

THE DEPTH TO WHICH THE TEAT DIPS INTO THE LINER A LARGE IMPACT ON THE MASSAGE EFFECT AND THEREFORE MILKING DURATION AND MILK-OUT QUALITY. THIS PARTICULARLY AFFECTS VERY SHORT TEATS WITHIN A HERD.

Liner barrel shapes – it's what's inside that counts

So you've chosen the size and material for your liners. But what about the inside of them? Or to put it another way: which barrel shape is best for your herd?

Generally, you can choose between cylindrical (straight) and conical (tapered) models. The decision you make will depend on the most common teat size within your herd – choose a model that matches around 80 percent of the cows. In inhomogeneous herds, where a relatively equal number of cows have straight and tapered teats, the tapered version is the better choice as its funnel shape can adapt to a wider variety of shapes.

Round liner range with corners and edges

GEA's round liners are designed to cover the teats completely. This ensures a secure grip with perfect stimulation and massaging effects, as well as ideal milk flow rates and yields.

Non-round GEA liners do not cover the entire teat. A disadvantage? Not at all. They work just as well as the round liners, just in a different way. The massaging effect does not work directly on the teat canal, which reduces the mechanical

strain on the canal during the liner's massage phase. This can help you to improve teat condition within herds that are more prone to hyperkeratosis. But remember: non-round liners still have to fit the herd and be configured correctly.

The primary difference between the round, triangular and square liners is the way they collapse to massage the teat.

The perfect combination: the innovative GQ liner

New and unique: the innovative design of the GEA GQ (Gentle and Quick) liner combines the best features of round and non-round barrel shapes. The benefits of the GQ liner? An optimum massaging effect throughout the entire milking process, appropriate levels of stimulation, a secure hold without air leakage and additional re-positioning of the milking claw, and support of efficient milking.



Liners for Classic claws

The Classic 300 and Classic 300 Evolution (E) are GEA's all-rounder milking unit. Dairy farms all over the world trust these tried and tested milking claws primarily due to their robust and easy-to-use design.

Both milking units are designed for simple milk processing with direct, un-diverted milk flows. One thing that is very important for you as a farmer: as with all GEA milking units, we offer a special range of liners for the Classic 300 and Classic 300 E systems that you can use to customise your parlour and react quickly to changing requirements, such as new udder shapes and teat sizes.

The perfect Classic fit

The Classic 300 is best suited to cows with normal to wide teat positions. But if you have modern, high-performance cows with narrow standing rear teats, the Classic 300 E is the perfect choice as the short milk hoses are positioned closer together.

Your benefit: the largest range of liners ...

Ensure your Classic milking unit suits your herd perfectly with GEA's largest liner portfolio – available in rubber as the ClassicLiner and in silicone as the ClassicPro. Another plus for this liner range: to help you fine-tune your liner/milking unit combination, you can also pick from single- and multi-piece versions, round and non-round as well as cylindrical and conical models.

SINGLE-PIECE OR MULTI-PIECE LINERS?

Whether you choose a single- or multi-piece liner has no impact on milk yields. It is more about adapting to the needs of your herd and your personal preferences.

- Multi-piece: comprises the liner, sight glass and a short milk hose and has to be assembled from the individual components.
- Single-piece: no sight glass. The short milk hose is connected directly to the liner.



I REALLY LIKE THE LARGE RANGE OF CLASSIC LINERS. IT'S PERFECT FOR ADAPTING MY MILKING UNIT TO THE CHANGING NEEDS OF MY HERD.

Hauke Bornholdt, Rederstall/Germany, 150 cows



ClassicPro silicone liners

The flexible lip of the single- and multi-piece ClassicPro silicone liners adapt to any teat shape and thus is gentle on the udder during milking. The ClassicPro range offers the right liner for every teat size. Single-piece and multi-piece ClassicPro silicone liners come in various sizes, with different options for barrel, mouthpiece opening and outer head diameters.

Your benefits: long-lasting, resistant silicone for high milk flows, optimum teat condition and an ideal milk out.

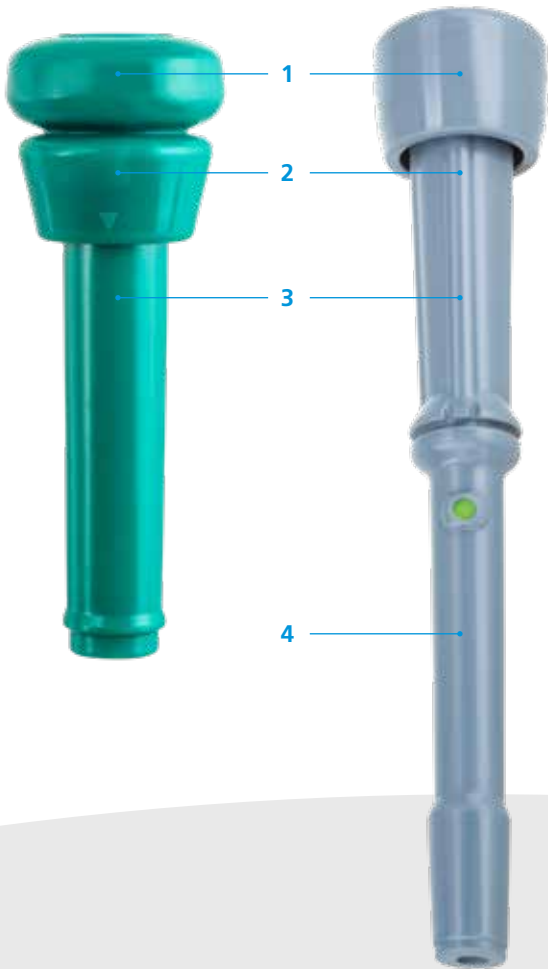

- 1 Flexible mouthpiece
- 2 Unique design for efficient milking
- 3 Optimum adaptability
- 4 Flexible milk hose for optimum positioning

ClassicLiner rubber liner

The ClassicLiner is available as a one-piece rubber liner or as a multi-piece version with sight glass and short milk hose. The single-piece and multi-piece ClassicLiner is available in various sizes, with different options for barrel, mouthpiece opening and outer mouthpiece diameters.

All ClassicLiner models provide a perfect fit – even for small teats. Your benefits: improved adhesion to the teats with less slippage and air leakage, so cows are milked out more ideally.



- 1 Rubber liner
- 2 Sight glass
- 3 Short milk hose

Single-piece rubber liners do not have a sight glass. Hence the short milk tube is connected directly to the liner to form a single unit.

Liners for the IQ claw

This quartet is in a league of its own. The IQ milking unit from GEA is fitted with revolutionary four-way technology, designed specifically to match the natural udder structure. The milk flows quickly and directly to the outlet from each individual udder quarter.

These liners enable you to milk your high-performance cows more efficiently, whilst also reducing the risk of teat-to-teat contamination with mastitis pathogens.

Unique: individual liner attachment, without the vacuum cleaner effect

Another unique feature: the suction of the vacuum is blocked by stainless steel balls when the teat cup is not attached. This also prevents impurities such as manure and dirt from being sucked into the milk line. Easy to use? Definitely. Easy attachment, easy milking, easy maintenance. Which means maximum milk quality, quantity and udder health.

Exclusive liners for IQ milking units

The choice is yours: the series is comprised of the IQPro silicone and IQLiner rubber liners, both of which have been developed exclusively for IQ milking units. One of the many advantages of these

single-piece liners is that the special mouthpiece design not only provides optimum grip, but is also incredibly flexible so it can adapt to different udder shapes.

UNIQUE LINER DESIGN

IQPro silicone and IQLiner rubber liners work together with IQ milking units to provide reliable, animal-friendly milking whilst support keeping the teats in the best condition possible.

- Versatile mouthpiece design
- Integrated and patented shock absorber (IQPro)
- Anti-twist solutions at the shell
- Patented and flexible milk hose
- Nozzleless connection to the claw
- Clear, engraved fitting marking on the mouthpiece

“

MILKING WITH THE IQ IS INCREDIBLY COMFORTABLE AND TIME-SAVING FOR ME. THE LINERS SIT PERFECTLY ON EVERY TEAT WITHOUT SLURPING SO I DON'T HAVE TO WORRY ABOUT REPOSITIONING THEM ...

Friedrich GbR, Drolshagen/Germany, 150 cows



IQPro silicone liners

IQPro silicone liners are made from high-tech silicone, making them almost as flexible and adaptable as your own hand. The IQPro's uniquely flexible mouthpiece fits gently onto all teat shapes and creates a reliable seal on the bottom of the udder. The silicone liner always retains its elasticity regardless of the ambient temperature, which means that its milking properties remain constant, guaranteeing continuous high performance.

The one-piece IQPro is available in a range of different barrel shapes and sizes with a variety of barrel and mouthpiece opening diameter options to choose from.

IQLiner rubber liners

The way the IQLiners attach individually to your IQ milking unit is completely unique. The tried and tested rubber material ensures that the IQLiner works reliably whilst being gentle on the teat, with optimum adhesion and flexibility on the udder.

To ensure that your IQ milking unit adheres perfectly to the udder, you can choose from three sizes of IQLiner, including a conical version that is particularly suited to growing dairy farms with inhomogeneous teat sizes.

WHETHER YOU USE IQPRO SILICONE OR
IQLINER RUBBER LINERS, THE INDIVIDUAL
DESIGN MEANS THAT YOU CAN TAKE
ADVANTAGE OF ALL OF THE KEY MILKING
BENEFITS YOUR IQ MILKING UNIT PROVIDES.

- 1 Secure and problem-free assembly: anti-twist feature and clear installation marking for complete clarity
- 2 Secure and fast assembly: anti-twist feature and integrated and patented shock absorbers protect the silicone material from damage
- 3 Perfect positioning: narrowing directly below the shell and a specially pre-formed milk hose help to ensure perfect positioning
- 4 Maximum flexibility for good adhesion: nozzleless connection to the claw without an sight glass ensures correct and flexible positioning during milking; thickening at the end of the short milk hose ensures that the shells drop away evenly

IQPro silicone liners

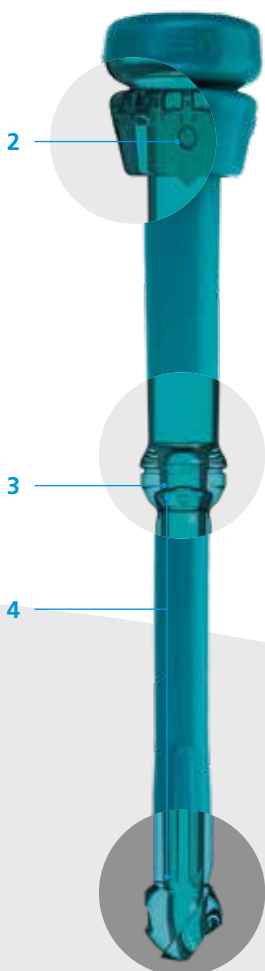

IQLiner rubber liners

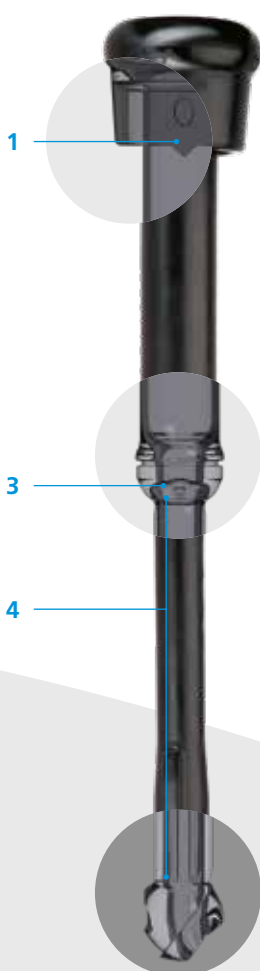

Liners for the ApolloMilkSystem

With the patented ApolloMilkSystem, you're milking in First Class with your conventional parlour. It is the first system of its kind to offer an automated post-dipping and disinfection process in conventional parlours without affecting milk quality.

This solution is as easy to use as it is practical and safe: automated dipping and a back flushing after removal are all carried out via the liner mouthpiece. It works like this: the ApolloMilkSystem carries out a dipping procedure on each teat while it is still in the liner after milking. This means that the entire teat surface, including all wrinkles and bumps, is perfectly coated and protected when the cow goes back into the outside environment. So you benefit in two ways: you don't have to do as much time-consuming work, and your herd's health is protected automatically.

Based on the IQ 4-way milking unit

The ApolloMilkSystem uses the separate four-way technology of the IQ claw to combine automated dipping, cleaning and disinfection with a fast, safe and gentle milk out of each individual quarter.

ApolloQLiners for the ApolloMilkSystem

The single-piece rubber liners in the ApolloQLiner range are available in a variety of sizes with various barrel and mouthpiece opening diameter options. This ensures maximum flexibility and adaptability to different teat and udder shapes.

YOUR BENEFITS AT A GLANCE

- Automated dipping, rinsing and disinfection in a single milking process
- Removes around 95 % of all potential pathogens
- Automated work routine with consistent levels of safety
- Precise, economical dipping agent dosage
- Quiet, ergonomic and stress-free milking

“

I WAS REALLY IMPRESSED WITH HOW EASY IT IS TO USE. THE APOLLO LINERS ARE DELIVERED READY FOR INSTALLATION AND YOU CAN REPLACE THEM QUICKLY WITHOUT ANY TOOLS.

Andreas Richter, AG Dobra/Sachsen/Germany, 1,050 cows



ApolloQLiner rubber liners

With the ApolloQLiner, you can start straight away! Unlike other liners out on the market, you don't need additional time for installing further equipment such as ventilation systems or dipping nozzles. Everything you need for automated dipping and backflushing with the ApolloQLiner is right there inside the liner itself.

Another plus-point:

the oval barrel shape determines the direction in which the barrel of the liner collapses. This means that the liner barrel is prevented from touching the shell's inner dip channel as it moves.

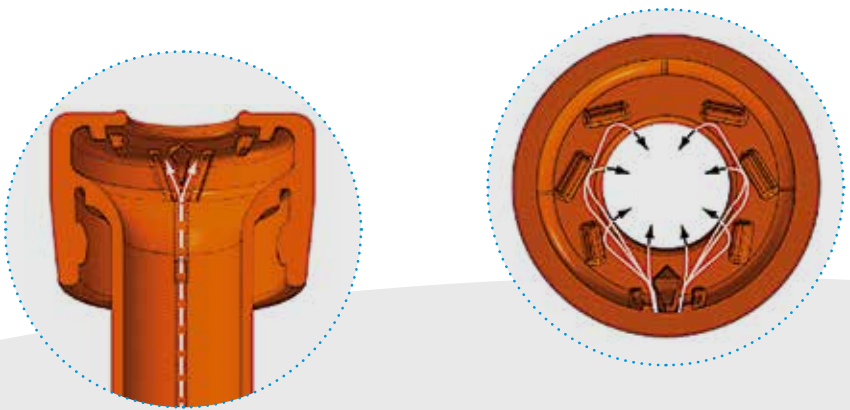

THE DIPPING PROCESS WITH THE GEA APOLLOQLINER

The dipping agent is injected onto the underside of the liner lip. The patented design of the liner mouthpiece ensures that the dipping agent flows evenly around the teat. Applying the dipping agent at the base of the teat ensures complete coverage before the teat is exposed to external influences.

- 1 Patented mouthpiece for optimum dipping and milking results
- 2 Efficient, unrestricted milking: the oval barrel determines the massage direction to prevent it from hitting the inner dip channel in the shell without influencing milking performance
- 3 Perfect positioning: narrowing directly below the shell and specially pre-formed milk hose help to ensure perfect positioning
- 4 Maximum flexibility means good adhesion: nozzleless connection to the claw without an sight glass ensures correct and flexible positioning during milking; thickening at the end of the short milk hose ensures that the shells drop away evenly

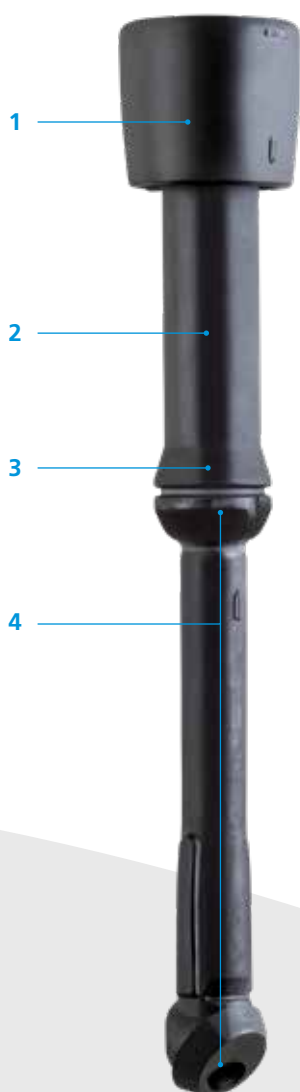
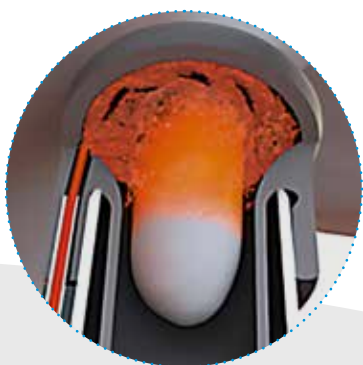

Liners for GEA automated milking systems (AMS)

More time for what's important – more and more dairy farmers are enjoying the benefits of GEA's automated milking systems. For you, this might mean having more time for herd management or your family and hobbies.

The global trend toward automated milking systems continues. GEA's AMS solutions offer an enticing combination of easier working processes and more flexible working hours – for operations of any size. This makes them an exciting alternative to conventional milking technologies as they allow you to milk your herd more than twice a day with minimal effort.

Unique all-in-one process inside the liner

What makes milking with an automated milking system from GEA so different? The entire milking process, from preparation to detachment, takes place automatically inside the liner. Once attached to the udder, all of the subsequent steps are carried out inside the silicone or rubber liner: cleaning, stimulation, fore-stripping, milking and dipping.

ON THE SAFE SIDE, AUTOMATICALLY ...

This technically sophisticated all-in-one process from GEA is unique amongst automated milking systems worldwide, and therefore requires specially-designed liners. We have developed a range of silicone (AMSPRO) and rubber (AMSLiner) liners that covers all of the different barrel, mouthpiece opening and mouthpiece diameters you could need to ensure they fit your animals' teats perfectly. So you can milk successfully, every time.

“

WITH ITS SMALLER MOUTHPIECE CHAMBER,
THE AMSPRO ALSO ATTACHES SECURELY
TO SMALL AND SHORT TEATS AND PROVIDES
AN OPTIMAL MILKING RESULT.

Petra Grunewald, Agrargenossenschaft Linda/Germany, 920 cows



The all-rounders: AMSPro and AMSLiner

The AMSPro and AMSLiner are all-rounder liners that can manage the recommended manual milking steps for you automatically. Like every GEA liners the AMSPros and AMSLiner are intensively tested, assessed and certified. Hence, using them guarantees you lasting functionality and a consistent milking routine for every milking procedure, whilst adhering to all hygiene standards applicable to dairy farms.

- 1 Udder health: various mouthpiece geometries to choose from to ensure consistent dipping results – reliable protection of the udder over the entire lifespan
- 2 Adaptability and efficiency: various shapes and sizes allow optimum adaptation to teat sizes. So nothing should stand in the way of efficient milking!
- 3 Performance: all materials undergo long-term on-farm testing and meet all common food safety standards

AMSPro silicone liners

AMSLiner rubber liners



All-in-one process: 6 steps

1. Attachment



2. Cleaning



3. Stimulation



4. Fore-stripping



5. Milking



6. Dipping



Simple and efficient: in 10 steps to a good milking routine

Everyone wants to milk their cows well – and it's easy if you just keep an eye on a few important things. As well as having the right milking equipment, a consistent milking routine also plays a critical role. We recommend ten easy steps to help you maintain the health and performance of your animals whilst achieving a profitable, high-quality yield. Just remember: always wear gloves!



1. Cow entrance

Relaxed entry to the milking parlour without excessive driving. The reason: stress impedes the effect of the milk production hormone oxytocin, the animals are agitated and milk flow can be restricted or blocked.



2. Udder preparation

Check for swollen udder quarters and injured teats early in the process. As with all subsequent steps: always wear gloves!

3. Pre-dipping and cleaning

Pre-clean the udder if excessively dirty. If using pre-dip, dip all four teats (min. 75% of the teat) and allow contact time (20 – 30 seconds). Important: the first touch of the udder stimulates the release of milk.



4. Fore-stripping

Operators should strip one to three streams of milk from each teat individually and check for flakes or clots.





10. Cleaning

Once the cows have left the parlour, clean the deck and all of its components automatically or manually. Removes pathogens and improves milk quality.

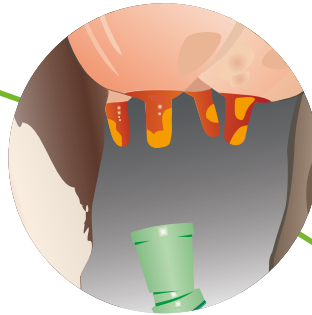

9. Post-dipping

After the milking unit has been removed, apply a post-dip agent to the teats so that it covers at least 75 % of the surface. This provides protection from pathogens after milking and between milk phases.

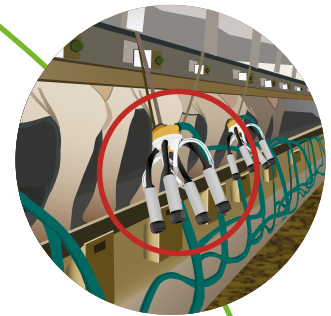

8. Milking unit removal

If the milk flow reaches or falls below the given threshold, remove the milking unit. Use automated detachment and avoid overmilking.



7. Milking

Avoid fall-off of the liners and air leakage. Reposition if necessary.

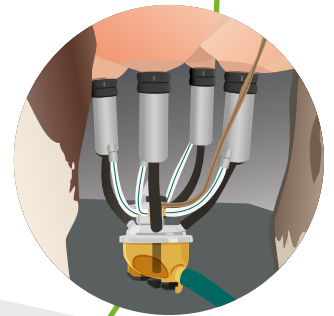

6. Milking unit attachment

The milking unit should be attached 60 to 90 seconds after the udder is first stimulated. Adjust the unit so it hangs squarely under the udder. Look for an even milk flow from all four udder quarters.

5. Wipe

Wipe the teats downward to dry them thoroughly with a soft udder cloth. Important: do not forget the teat tips, which are particularly susceptible to pathogens.

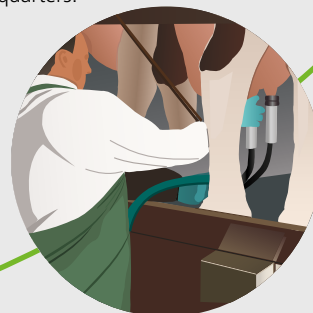

Better to be safe than sorry: always keep an eye on replacement intervals

Treat your liners as you would do your car tyres: even the best materials will eventually start to wear. Changing them at the right time helps to ensure the performance and quality of your milking process.

How long a liner lasts depends largely on its material and how long it is used for. But you are always on the safe side if you keep to GEA's recommended replacement intervals. Rubber liners should be replaced after a maximum of 750 hours of use or 2,500 milkings, and silicone liners after a maximum of 1,500 hours or 5,000 milkings.

Replace late, face the consequences

The liner is one of the most active parts of the milking unit, opening and closing millions of times over its lifespan. This huge amount of work wears away on the material and causes changes you may not recognise straight away, such as in the shape of the liner, its tension and flexibility and the condition of the surfaces.

If the liner is replaced too late, microscopic or even visible cracks can form in the barrel and short milk hoses, which then become ideal breeding grounds for pathogens. The tension in the barrel may also become too low. Possible consequences of this could be an insufficient massaging effect and milk flow, and deformation of the lip that increases the risk of the claw slipping during milking.



Silicone liners
1,500
hours
5,000 milkings

Rubber liners
750
hours
2,500 milkings

REPLACE LATE AND FACE THE CONSEQUENCES

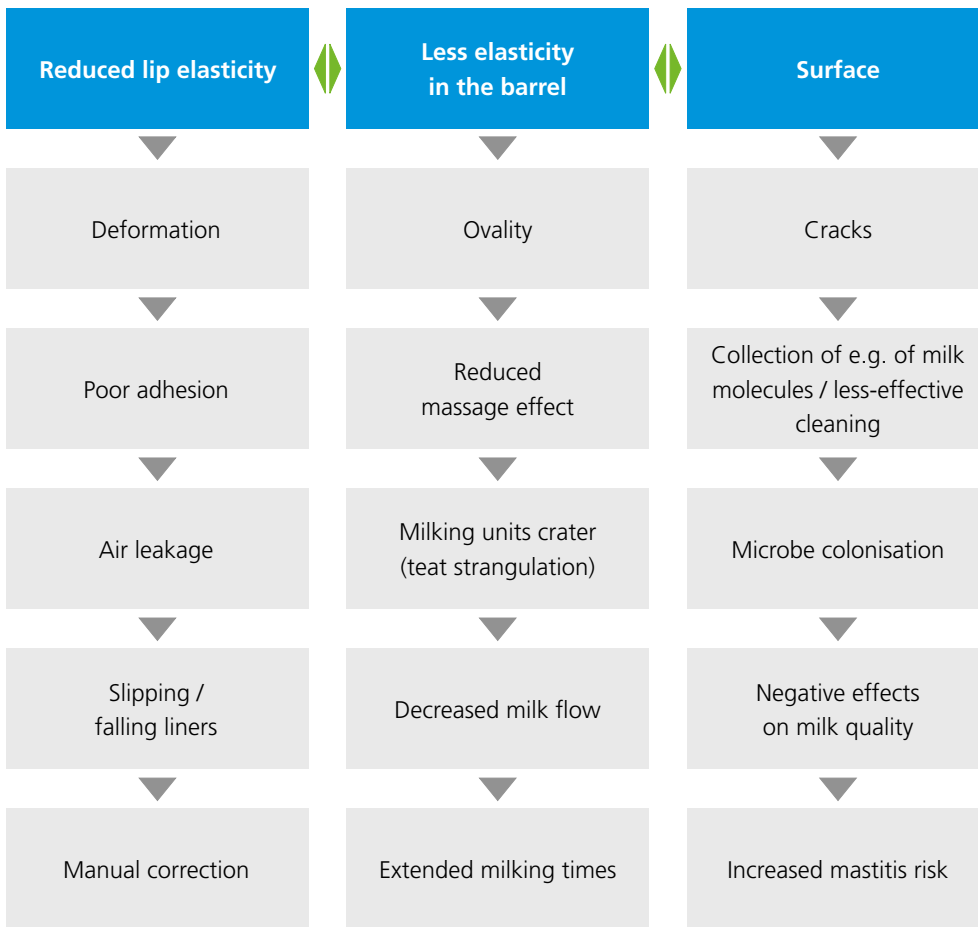

LOWER MILK YIELDS AND LONGER MILKING TIMES

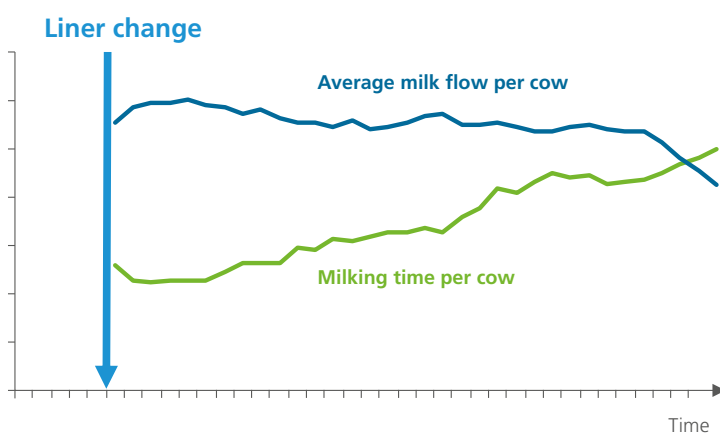





















Changing a liner too late has a negative impact on milk characteristics: milk flows and yields fall, milking times lengthen. The consequences: the herd's performance potential is not fully taken advantage of, the milk quality can drop and the risk of mastitis increases.

DETERGENTS AND DISINFECTANTS

















Important for optimal liner life: always use the detergents and disinfectants recommended by GEA in the recommended dosage. If you exceed the recommended dosage, it can affect the condition and performance of the liner, and therefore its lifespan.

Overview of the GEA liners

GEA ClassicPro silicone liner, multi-part (long Classic teat cup shell 147 mm)



















	Material no.	Delivery unit	Description*	Teat diameter	Teat shape	
Wide – slim		7029-2725-030	4 x 100 x	23 / 20 / 62 	 19 – 24 mm	
		7029-2725-150	4 x 100 x	24 / 21 / 58 	 20 – 26 mm	
		7029-2725-000	4 x 100 x	25 / 22 / 62 	 21 – 27 mm	
		7029-2725-010	4 x 100 x	25 / 23 / 62 	 21 – 28 mm	
		7029-2725-020	4 x 100 x	27 / 25 / 62 	 23 – 29 mm	

GEA ClassicPro silicone liner, one-piece (teat cup shell 140 mm)









	Material no.	Delivery unit	Description*	Teat diameter	Teat shape	
Wide – slim		7770-1012-400	100 x	21 / 20 / 51 	 18 – 25 mm	
		7770-1012-600	100 x	21 / 20 / 51 	 18 – 25 mm	
		7769-3025-501	100 x	23 / 20 / 51 	 19 – 28 mm	
		7769-3025-502	100 x	23 / 20 / 51 	 19 – 28 mm	

*Brief description: Barrel diameter (mm) / mouthpiece opening (mm) / outer mouthpiece diameter (mm)

















GEA ClassicLiner rubber liner, multi-piece (long Classic teat cup shell 147 mm)

	Material no.	Delivery unit	Description*	Teat diameter	Teat shape
Wide – slim	7021-2725-350	4 x 100 x	24 / 22 / 58 	 18 – 26 mm	
	7021-2725-190	4 x	25 / 20 / 58 	 21 – 24 mm	
	7021-2725-230	4 x 100 x	27 / 23 / 58 	 21 – 28 mm	
	7021-2725-220	4x 100 x	27 / 23 / 58 	 22 – 30 mm	
	7022-2725-150	4 x 100 x	27 / 25 / 66 	 23 – 32 mm	
	7022-2725-180	4 x	27 / 25 / 66 	 24 – 33 mm	













GEA ClassicLiner rubber liner, one-piece (long Classic teat cup shell 147 mm)

	Material no.	Delivery unit	Description*	Teat diameter	Teat shape
Wide – slim	7021-2725-370	4 x	25 / 22 / 58 	 20 – 26 mm	
	7021-2725-029	100 x	26 / 22 / 58 	 21 – 27 mm	
	7021-2725-240	4 x	27 / 23 / 58 	 21 – 28 mm	













GEA IQPro silicone liner (IQ teat cup shell 140 mm)

	Material no.	Delivery unit	Description*	Teat diameter	Teat shape
Wide – slim	 7765-3025-501	100 x	23 / 20 / 51 	 19 – 28 mm	
	 7025-2725-010	4 x 100 x	24 / 21 / 58 	 20 – 26 mm	
	 7025-2725-000	4 x 100 x	25 / 22 / 62 	 21 – 27 mm	
	 7025-2725-020	4 x 100 x	27 / 25 / 62 	 23 – 29 mm	

GEA IQLiner rubber liner (IQ teat cup shell 140 mm)













	Material no.	Delivery unit	Description*	Teat diameter	Teat shape
Wide – slim	 7024-2725-350	4 x 100 x	24 / 22 / 58 	 18 – 26 mm	
	 7024-2725-029	4 x 100 x	26 / 22 / 58 	 21 – 27 mm	
	 7024-2725-220	4 x 100 x	27 / 23 / 58 	 22 – 30 mm	

GEA ApolloQLiner rubber liner (ApolloIQ teat cup shell 140 mm)













	Material no.	Delivery unit	Description*	Teat diameter	Teat shape
Wide – slim	 7030-2725-789	100 x	22 / 21 / 51 	 18 – 24 mm	
	 7030-2725-790	100 x	24 / 22 / 51 	 20 – 26 mm	
	 7030-2725-029	100 x	26 / 22 / 58 	 21 – 27 mm	

*Brief description: Barrel diameter (mm) / mouthpiece opening (mm) / outer mouthpiece diameter (mm)

GEA AMSPro silicone liner (and Mlone teat cup shell from Revision R-C onward)

	Material no.	Delivery unit	Description*	Teat diameter	Teat shape
Wide – slim	 7801-2725-090	4 x 100 x	25 / 21 / 58 	 20 – 26 mm	
	 7801-2725-110	4 x 100 x	24 / 21 / 58 	 20 – 26 mm	
	 7801-2725-100	4 x 100 x	25 / 22 / 62 	 21 – 27 mm	

GEA AMSLiner rubber liner (and Mlone teat cup shell from Revision R-C onward)

	Material no.	Delivery unit	Description*	Teat diameter	Teat shape
Wide – slim	 7801-2725-350	4 x 100 x	24 / 22 / 58 	 18 – 26 mm	
	 7801-2725-029	4 x 100 x	26 / 22 / 58 	 21 – 27 mm	
	 7801-2725-220	4 x 100 x	27 / 23 / 58 	 22 – 30 mm	

We live our values.

Excellence • Passion • Integrity • Responsibility • GEA-versity

GEA is one of the largest technology suppliers for food processing and a wide range of other industries.

The global group specializes in machinery, plants, as well as process technology and components.

GEA provides sustainable solutions for sophisticated production processes in diverse end-user markets and offers a comprehensive service portfolio.

The company is listed on the German MDAX (G1A, WKN 660 200), the STOXX® Europe 600 Index and selected MSCI Global Sustainability Indexes.

GEA Deutschland

GEA Farm Technologies GmbH

Siemensstraße 25 - 27

59199 Bönen, Germany

Tel +49 23 83 93 7-0

Fax +49 23 83 93 8-0

info@gea.com

gea.com