

200 SERIES SKID STEER LOADERS & COMPACT TRACK LOADERS



L213 | L216 | L218 | L220 | L221 | L228 | L234
C227 | C232 | C234 | C238



Powerfully Compact 200 series.

The 200 series of skid steer loaders and compact track loaders are the evolution of New Holland skid steer loader design. The unique New Holland concept delivers comfort and performance in a compact package:

- Compact dimensions – under 2m high & just over 1.5m wide on the smallest model
- Excellent stability and weight distribution maximise performance and safety
- All round visibility ensures high manoeuvrability and faster work cycles
- Comfort Deluxe Cab features excellent ergonomics and best-in-class comfort
- Wheels or tracks, Super Boom™ or Radial Lift - the choice is yours



In 2017 New Holland produced its 250,000th skid steer loader. The manufacture of New Holland skid steer loaders began 45 years ago in North America, and to this day we pride ourselves as being the pioneers of the Super Boom design concept, offering best in class forward reach and lift height combined with unparalleled operator safety.



Models	Power (hp)	Max lift height (mm)	Tipping load (kg)	Width (mm)	Height (mm)	Operating weight (kg)	Rated Operating Capacity (kg)	Boom design
L213	49	2845	1179	1518	1919	2300	590	Radial Lift
L216	61	2845	1455	1518	1919	2505	725	Radial Lift
L218	61	3048	1633	1678	1974	2832	818	Super Boom
L220	68	3073	1814	1755	1998	2930	905	Super Boom
L221	75	3124	1814	1755	1998	3160	905	Radial Lift
L228	75	3287	2540	1768	2002	3740	1270	Super Boom
L234	91	3327	3090	1930	2042	4136	1545	Super Boom
C227	75	3124	2449	1676	1998	3720	1225	Radial Lift
C232	75	3330	2900	1930	2043	4370	1450	Super Boom
C234	91	3215	3080	1930	2043	4536	1540	Radial Lift
C238	91	3327	3447	1930	2043	4581	1723	Super Boom

Built around you.

New Holland 200 series are built around you with reliable engines that deliver a more powerful performance, whilst using less fuel than previous models. They are durable, easy to maintain and will reduce your operating costs. Three different auxiliary hydraulics packages give maximum versatility. Offering class leading space, comfort and ergonomics, the Comfort Deluxe Cab also affords excellent all round visibility and reduced blind spots.

Fully sealed cab option with heating and air-con.

Bolt on counterweights to the rear corners of the machine for flexible ballasting.

55% more hydraulic capacity with High-Flow option.

C227 & C238 models feature rubber tracks and a robust undercarriage, with few moving parts and self lubricating rollers.

Mechanical or EH customizable controls with adjustable speed and sensitivity.

Self levelling and Glide ride ensure accuracy and operator comfort.

Super Boom™ or Radial Lift

Super Boom™ vertical lift design for loading and carrying.
Radial Lift for digging and pushing.

Wide cab entrance with low entry threshold.

High visibility thanks to the large windows and narrow cab pillars.

Powerful, low emission engines.

Hydraulic quick coupler option.

Longer wheelbase for outstanding stability.



Fast in execution, smooth in operation.

The New Holland skid steer loader & compact track loader ranges feature a total of 11 models, with operating loads ranging from 590kg to 1723kg, and lift heights from 2.85m to 3.3m. New Holland knows that these machines will be used in a wide variety of applications, so have been engineered by design to offer versatility as standard. Whether you are handling bales, sweeping yards, feeding your cattle in winter or snow blowing, you've found your perfect farming partner, that will boost your productivity with fast cycle times resulting from its perfect balance, excellent stability and powerful hydraulic system.



Best-in-class boom geometry

The New Holland 200 series feature Radial Lift or Super Boom™ models, to cater for the specific needs of your business.

- For loading & lifting, the patented vertical lift geometry of the Super Boom system enables operators to load material far beyond the reach and height of most other skid steer loader designs. The exceptional forward reach afforded by this design makes loading bales and reaching over feed barriers an effortless task
- For pushing & digging, the Radial Lift geometry gives outstanding power through the direct connection of the boom with the frame. Productivity in applications such as manure handling, soil moving and yard scraping is boosted by their outstanding breakout force



Comfort Deluxe Cab

The Comfort Deluxe Cab offers up to 25% more internal width than competition with greater head room and leg room. In addition, a fully sealed and pressurized cab minimizes noise, dust and exhaust infiltration. The low noise levels will be appreciated by people within the working range of the machine.



All around visibility

A comprehensive view of the job site makes it easier for you to work productively and safely. The 200 series deliver:

- Clear and unobstructed view of the attachment and bucket edge
- Large visibility panel in the cab roof for a clear view of the attachment at full height
- High visibility mesh side screens
- Narrow cab pillars to maximize visibility



Versatility and ergonomics

A choice of control style is available: mechanical or electro-hydraulic controls can be selected.

- Electro-hydraulic controls are switchable between ISO to H pattern
- Speed and sensitivity settings for travel, boom & bucket can be fine tuned
- Armrests can be adjusted up or down
- Joystick position can be adjusted both vertically and horizontally



Easy maintenance

Maintenance and servicing on 200 models couldn't be easier, access for engine and hydraulic oil changes is via a removable cover on the left rear quarter.



Environmentally friendly.

New Holland 200 series comply with Tier 4A & Tier 4B regulations, cutting emissions levels, with over 90% less particulate matter (PM) and 50% less nitrogen oxide (NOx) than the previous generation. In addition, when you don't need the full power of the machine, the variable flow hydraulic pump only uses the power required leading to significant extra-fuel savings as well as reduced operating noise.

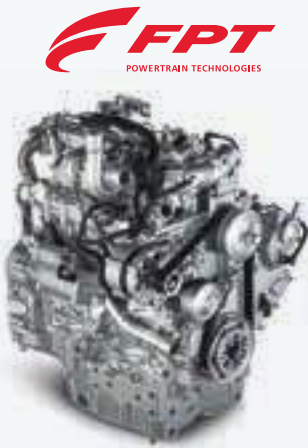

- Diesel PM (particulate matter) Catalyst traps the residual particulate contained in the exhaust gas of the engine.
- Cooled Exhaust Gas Recirculation (CEGR) process is now controlled electronically to achieve greater performance and fuel efficiency, as well as even greater reliability - for example, to help protect the engine from overheating.
- The external Cooled EGR (Exhaust Gas Recirculation) system ensures efficient air handling and high engine power density with the shortest load response time
- Diesel Oxidation Catalyst (DOC) utilizes a chemical process in order to break down pollutants from diesel engines in the exhaust stream, turning them into less harmful components. DOC does not require regeneration and it is a maintenance-free component.
- Diesel Particulate Filter (DPF) physically traps particulate matter from the engine exhaust. Electronic controls will trigger an automatic regeneration of the DPF system. Additionally, the system can notify the machine operator to manually regenerate the DPF system occasionally when the soot load in the DPF exceeds the range defined for automatic regeneration.

Models	Power (hp)	Engine	Displacement (l)	Emission Level	Tier 4 Technology
L213	49	ISM N844L-F IDI	2.2	Tier 4A / Stage 3B	-
L216	61	ISM N844LT-F IDI	2.2	Tier 4B / Stage 4	CEGR + DPF + DOC
L218	61	ISM N844LTA-DI-F	2.2	Tier 4B / Stage 4	CEGR + DOC
L220	68	ISM N844LTA-DI-F	2.2	Tier 4B / Stage 4	CEGR + DOC
L221	75	FPT F5H HPCR	3.4	Tier 4B / Stage 4	CEGR + DOC
L228	75	FPT F5H HPCR	3.4	Tier 4B / Stage 4	CEGR + DOC
L234	91	FPT F5H HPCR	3.4	Tier 4B / Stage 4	CEGR + DOC
C227	75	FPT F5H HPCR	3.4	Tier 4B / Stage 4	CEGR + DOC
C232	75	FPT F5H HPCR	3.4	Tier 4B / Stage 4	CEGR + DOC
C234	91	FPT F5H HPCR	3.4	Tier 4B / Stage 4	CEGR + SCR
C238	91	FPT F5H HPCR	3.4	Tier 4B / Stage 4	CEGR + SCR

L200 SERIES SKID STEER TYRE OPTIONS



Models	Over Tyre width (mm)	L213	L216	L218	L220	L221	L228	L234
Tyre description								
10X16.5 HVY DUTY 590TW	1500	•	•					
10X16.5 PREMIUM 590TW	1500	•	•					
10X16.5 HVY DUTY 640TW	1625			•	•	•		
10X16.5 PREMIUM 640TW	1625			•	•	•		
10X16.5 SEVER DUTY 640TW	1625			•	•	•		
10X16.5 NON-PNEU 640TW	1625	•	•	•	•	•		
10X16.5 TWEEL 640TW	1625	•	•	•	•	•		
12X16.5 HVY DUTY 700TW	1778			•	•	•	•	•
12X16.5 PREMIUM 700TW	1778			•	•	•	•	•
12X16.5 PREMIUM-LINER 700TW	1778			•	•	•	•	•
12X16.5 SEVER DUTY 700TW	1778			•	•	•	•	•
12X16.5 NON-PNEU 700TW	1778				•	•	•	•
12X16.5 TWEEL 700TW	1778					•	•	•
14X16.5 HVY DUTY 760TW	1930						•	•
14X16.5 PREMIUM 760TW	1930						•	•
14X16.5 SEVER DUTY 760TW	1930						•	•
31.5X13 FLOTATION 660TW	1678	•	•					

Ready for any job. Maximum choice, maximum versatility.

New Holland skid steers and compact track loaders do a lot more than lift and load. Take a look at the wide array of attachments, you'll quickly see how the versatility of these machines can make you more productive.



Hi-tip bucket



Pallet forks



4 in 1 bucket



Brush bucket



Backhoe



Snow blade



Snow blower



Hole borer



Slurry scraper



Muck fork



Heavy duty muck grab



Bale squeeze



Bale spike



FEATURES AVAILABLE FOR EASY ATTACHMENT USE

An optional hydraulic attachment coupler increases uptime and productivity on the farm by allowing operators to exchange attachments quickly and safely.

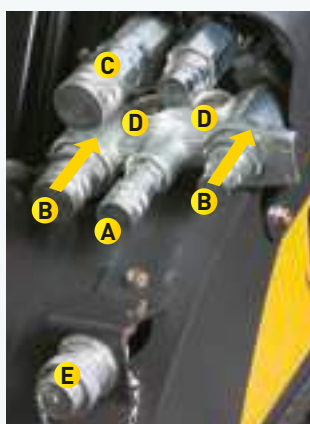

A connect under pressure CUP hydraulic manifold is standard equipment on all models for easy hook-up of all hydraulic attachments. By pushing on the fitting, you release pressure in both hydraulic lines.

- A** Hydraulic oil return (case drain).
- B** Hydraulic oil supply. These fittings slide into manifold and when pressed in, any pressure within the manifold is directed to the hydraulic oil reservoir.
- C** Drain line that flows to the tank.
- D** Pressure vents.
- E** 14-pin front electrical connection to control the most versatile attachments.

SPECIFICATIONS

Models		L213	L216	L218	L220	L221	L228	L234	C227	C232	C234	C238
Engine		ISM	ISM	ISM	ISM	FPT	FPT	FPT	FPT	FPT	FPT	FPT
		N844L-F IDI	N844LT-F IDI	N844LTA-DI-F	N844LTA-DI-F	F5H	F5H	F5H	F5H	F5H	F5H	F5H
Capacity	(l)	2.2	2.2	2.2	2.2	3.4	3.4	3.4	3.4	3.4	3.4	3.4
No of cylinders / Aspiration		4 / Natural	4 / Turbo	4 / Turbo	4 / Turbo	4 / Turbo	4 / Turbo	4 / Turbo	4 / Turbo	4 / Turbo	4 / Turbo	4 / Turbo
Emission level Tier / Stage		4A / 3B	4B / 4	4B / 4	4B / 4	4B / 4	4B / 4	4B / 4	4B / 4	4B / 4	4B / 4	4B / 4
Bore and Stroke	(mm)	84x100	84x100	84x100	84x100	99x110	99x110	99x110	99x110	99x110	99x110	99x110
Max Power	[kW/hp(CV)]	36.4/49	44.7/61	44.7/61	50/68	55/75	55/75	67/91	55/75	55/75	67/91	67/91
Rated engine speed	(rpm)	2800	2800	2800	2800	2500	2500	2500	2500	2500	2500	2500
Max. torque	(Nm)	143	188	183	208	314	314	383	314	314	383	383
Fuel tank capacity	(l)	60.5	60.5	73.8	73.8	73.8	96.5	96.5	96.5	96.5	96.5	96.5
Transmission		Hydrostatic single reduction chain drive										
Travel speeds low range	(kph)	11.9	11.9	11.9	12.5	11.4	11.4	12.4	9.3	8.2	8.2	8.2
high range (optional)	(kph)	-	-	17.4	18.3	16.9	16.9	18.5	13.4	12.2	12.2	12.2
Drive pump control		Direct mechanical or Electro-hydraulic										
Hydraulic system												
Pump flow	(lpm)	59	70	78	78	92	92	92	92	92	92	92
Optional high flow	(lpm)	-	-	116	116	126	143	150	143	143	143	143
Relief Pressure	(bar)	210	210	210	210	210	210	238	210	210	210	210
Weight												
Operating weight	(kg)	2300	2505	2832	2930	3160	3740	4136	3720	4370	4536	4581
Shipping weight	(kg)	2160	2370	2705	2840	3025	3430	3890	3340	4220	4380	3610
Performance specs												
Rated Operating Capacity (ROC)*	(kg)	590	725	818	905	905	1270	1545	1225	1450	1540	1723
Rated Operating Capacity (ROC) with weights*	(kg)	635	770	863	950	950	1400	1680	-	-	-	-
Tipping load	(kg)	1179	1455	1633	1814	1814	2540	3090	2449	2900	3080	3447
Lift cylinder breakout force	(kN)	12.7	14.7	11.7	15.3	20.3	27.3	30.8	27.0	21.5	34.5	27.2
Bucket cylinder breakout force	(kN)	18.6	23.4	24.7	32.5	32.3	38.3	41.5	32.3	32.7	38.7	32.7
Boom design		Radial Lift	Radial Lift	Super Boom	Super Boom	Radial Lift	Super Boom	Super Boom	Radial Lift	Super Boom	Radial Lift	Super Boom

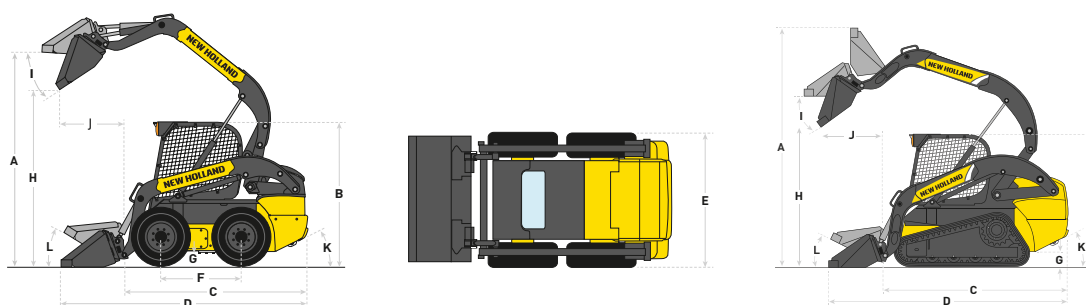

Models		L213	L216	L218	L220	L221	L228	L234	C227	C232	C234	C238
Reference configuration												
Wheels		10 x 16.5	10 x 16.5	10 x 16.5	12 x 16.5	12 x 16.5	12 x 16.5	14 x 16.5	-	-	-	-
Bucket		60" DF	60" DF	66" DF	72" DF	72" DF	72" DF	78" DF	72" DF	78" DF	78" DF	78" DF
Dimensions												
A - Max. lift height (bucket hinge pin)	(mm)	2845	2845	3048	3073	3124	3287	3327	3124	3330	3215	3327
B - Height	(mm)	1919	1919	1974	1998	1998	2002	2042	1998	2043	2043	2043
C - Length without attachment	(mm)	2435	2435	2685	2685	2669	2993	3021	2669	2993	3016	2986
D - Length with bucket*	(mm)	3028	3028	3352	3338	3292	3863	3652	3292	3631	3646	3624
E - Width	(mm)	1518	1518	1678	1755	1755	1768	1930	1676	1930	1930	1930
F - Wheelbase	(mm)	941	941	1128	1128	1128	1322	1322	-	-	-	-
G - Ground clearance	(mm)	178	178	178	203	203	203	243	-	-	-	-
H - Dump height	(mm)	2246	2246	2380	2405	2495	2615	2655	2495	2655	2602	2655
I - Dump angle	(°)	40	40	52	52	40	55	48	40	55	38	55
J - Dump reach @ max. height	(mm)	469	469	783	758	517	821	781	758	875	548	781
K - Angle of departure	(°)	22	22	23	25	25	24	27	25	32	32	27
L - Rollback angle (bucket on ground)	(°)	26	26	35	34	31	33	33	31	33	30	33

- Not applicable * 50% of tipping load



www.newholland.com/uk
www.newholland.com/ie



For more details, ask your New Holland dealer!

Calls to the Top Service team are free from landlines in the United Kingdom and Republic of Ireland. UK-based mobile calls are also free, but Republic of Ireland mobile users should call 01 2421881 and this will be charged at your standard network rate.

