



**AMAZONE**

Semi-mounted reversible ploughs ***Tyrok***



# Tyrok semi-mounted reversible ploughs

In-furrow or on-land - this plough sets new standards



❗ "The plough profile left behind the Tyrok was impressive."  
(profi Practice test. "Really good work..." · 05/2023)

❗ "The AMAZONE Tyrok 400 6+1 V offers a comparatively good price to performance ratio."  
(profi Practice test. "Really good work..." · 05/2023)

The Tyrok and Tyrok OL ploughs enable AMAZONE to offer unique advantages for your farm. Maximum speed with minimum wear is possible thanks to the new SpeedBlade plough bodies. At the same time, the new sturdy rectangular profile beam ensures a constant working depth over the full width. High levels of output are guaranteed with 6 to 9 furrows. The option of on-land ploughing means that the soil structure can be better protected in some conditions.



	Page
AMAZONE ploughs	4
The advantages at a glance	6
Tyrok and Tyrok OL semi-mounted reversible ploughs	8
The Tyrok design	10
Beam	12
Front furrow width	14
SpeedBlade plough bodies	16
©plus hardening process   Points	18
AMAZONE plough bodies	20
Overload protection	22
Furrow width adjustment	24
Support wheel	26
Equipment	28
Packers	30
Tyrok on-land semi-mounted reversible plough	32
AMAZONE service	34
Technical data	36

# AMAZONE ploughs

For intelligent crop production



## Ploughing today

The plough is symbolic in agriculture. Alongside crop establishment, fertilisation and plant protection, soil tillage plays a key role in the success of arable farming. Sustainability and a more efficient level of operation will be the decisive factors by which agriculture will be judged in the future.

The desire to maintain a sustainable soil structure, to increase productivity and, above all, to achieve higher profitability lies behind the design. The use of modern ploughs, alongside conservation tillage techniques and alternative sowing systems, remains at the forefront when it comes to improved yields and thus the success of any soil tillage operation.

AMAZONE ploughs are characterised by their robust build strength, an excellent quality of work, optimal adaptation to local conditions and thus offer the highest possible cost-effectiveness.

### The benefits:

- ✔ Individual matching of the plough to suit any application
- ✔ Simple adjustment and comfortable operation
- ✔ Long lifespan thanks to the robust construction

## Utilising the right technique is crucial!

It is not just the philosophy but the right choice of soil tillage method that is critical to success. Conventional sowing systems that are based on the use of the plough are still widespread. As a result of this and due to ever-changing parameters such as commodity prices, energy production, reduction of fallow vegetation, etc., many farms practice both conventional and mulch sowing methods in parallel. The yield-guaranteeing function of the plough is highly valued here.

## Advantages of inversion soil tillage

- ✔ Effective weed control via mechanical means by light deprivation, effective control around field borders
- ✔ Quicker soil warming and better soil aeration for increased yields in crops which demand higher soil temperatures
- ✔ The only soil tillage option in constantly wet conditions
- ✔ Reduced risk of disease carryover in the following crop
- ✔ Accelerates the microbial activity in the soil by oxygen enrichment
- ✔ Mechanical control of UV light sensitive soil pests, slugs and mice



# Tyrok and Tyrok On-Land semi-mounted reversible ploughs



33 – 55 cm/furrow

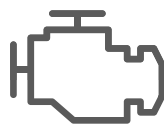

Up to 400 hp



Up to 10 km/h



6 to 9 furrows

# The advantages at a glance:

- + Exact working depth over the entire length of the plough thanks to the sturdy rectangular beam frame
- + **AutoAdapt** – automatic, precise adjustment of the front furrow width when changing the working width
- + Unique **SpeedBlade** plough bodies with its enlarged front shin of the mouldboard and the ©plus hardening process allow higher speeds with less wear
- + Fast turnover with low stress as a result of the **SmartTurn** two-stage hydraulic end position damping
- + The substantial support wheel ensures an exact depth control and the optimum soil structure protection
- + Maximum safety and comfort in the transport position due to standard damping of the support wheel
- + Centralised **SmartCenter** settings centre on the headstock of the plough for quick operation

## More advantages with the Tyrok On-Land:

- + Tool-free changeover by hand between on-land and in-furrow mode
- + Automatic centre of gravity reduction when turning

## MORE INFORMATION

[www.amazone.net/tyrok](http://www.amazone.net/tyrok)



PRODUCT FILM  
Find out more

# Meticulously designed from top to bottom

Tyrok and Tyrok OL semi-mounted reversible ploughs



## The models

With the Tyrok, AMAZONE offers a semi-mounted reversible plough with 6, 7, 8 or 9 furrows with either mechanical or hydraulic furrow width adjustment from 33 cm to 55 cm. Designed for use under the most arduous of conditions, the Tyrok is a robust plough with a high degree of comfort, thanks to its easy handling and adjustment. The Tyrok OL version offers the choice of ploughing on-land or in-furrow as required.

## The features at a glance

- ✔ 6, 7, 8 or 9 furrows
- ✔ For tractors up to 400 hp
- ✔ Over-dimensioned beam: 200x150x10 mm
- ✔ Standard with hydraulic front furrow width adjustment
- ✔ Shear bolt or hydraulic overload protection



Tyrok 400 VS

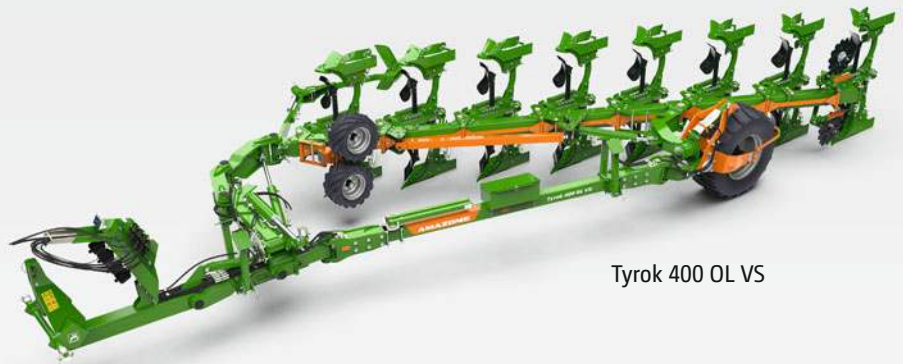

Tyrok 400 OL VS



## Overview of the Tyrok range:

	No. of furrows	Interbody clearance (cm)	Frame height (cm)	Furrow width adjustment (cm) manual working width	Furrow width adjustment (cm) hydraulic working width	Overload protection
Tyrok 400 / Tyrok 400 OL	6	100	80/85	35/40/45/50	–	Shear bolt
	7					
	8					
	9					
Tyrok 400 S / Tyrok 400 OL S	6	100	80	35/40/45/50	–	Hydraulic overload protection
	7					
	8					
Tyrok 400 V / Tyrok 400 OL V	6	100	80/85	–	33–55	Shear bolt
	7					
	8					
Tyrok 400 VS / Tyrok 400 OL VS	6	100	80	–	33–55	Hydraulic overload protection
	7					
	8					

# Comfortable operation – Precise working

The Tyrok design



! "All the hoses are guided to the tractor via a protective cover which can actually be varied in length."

(profi Practice test. "Really good work..." · 05/2023)

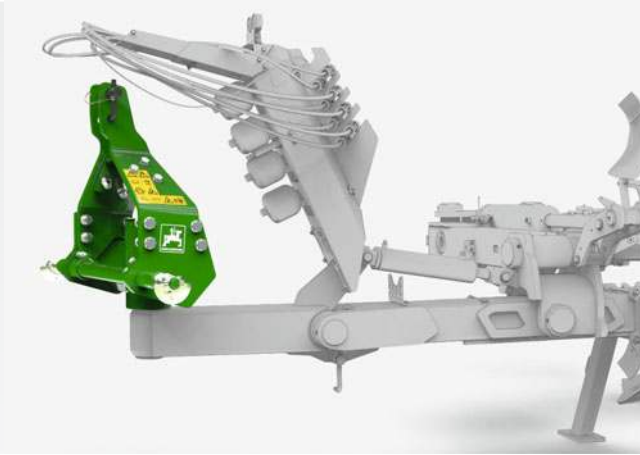

The Tyrok headstock

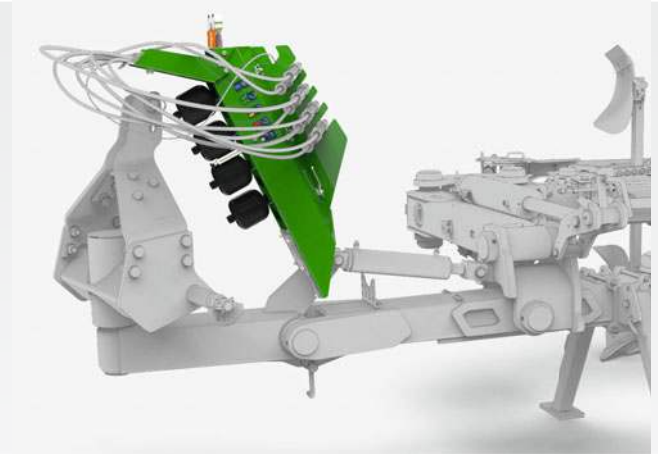

Tyrok SmartCenter

## Optimised headstock design

The headstock of the Tyrok provides the perfect link up to the tractor with the minimum of wear. The headstock is rotatable by 180°, which enables the side pull to be reduced, thereby saving fuel. Maximum flexibility is also provided by two coupling options for the top link as well as the lower link cross shaft in Cat. 3, 4N and 4. The Tyrok can also be equipped with traction control as an option. Here, another hydraulic cylinder transfers weight onto the tractor's rear axle thus increasing traction. This provides maximum pulling power whilst reducing fuel consumption.

## SmartTurn – smooth turnover in the shortest of time!

Thanks to its two-stage end-position damping, the plough's turnover process is slowed down shortly before reaching the end of its travel. This results in a damping effect which reduces stress on the materials when the cylinder is retracted. There is no need to make any compromises here as the low-stress turnover process is completed in just around 10 seconds.

## SmartCenter for comfortable adjustment

The uncluttered hose rail enables optimum hose routing to the tractor. So nothing stands in the way of quickly attaching the plough. In addition, all hydraulic functions can be controlled directly from the SmartCenter. This enables comfortable adjustment of the plough right at the front and directly on the machine.

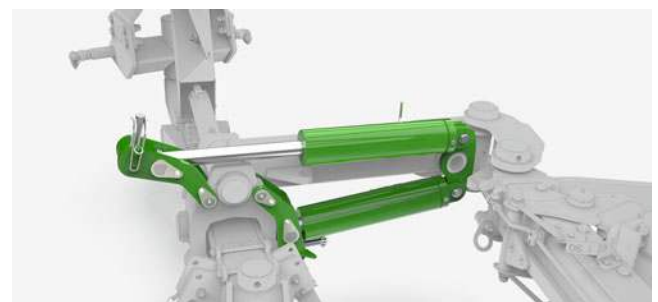

Turnover cylinder with hydraulic throttle valve



# The beam

Strength without compromise



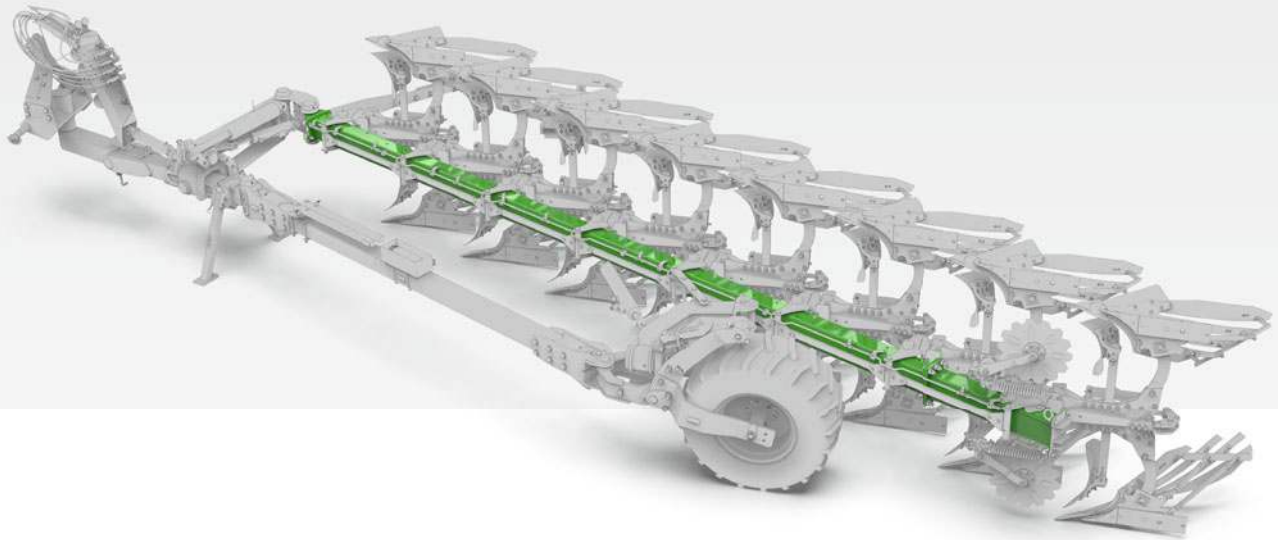

## The beam – pure strength

The rectangular, 200x150x10 mm dimensioned box section minimises any bending of the beam, even under heavy loads and hard soil conditions. The rigidity of the beam stops any bending, thereby ensuring the furrow depth remains constant across the entire plough width.

The rectangular profile also increases the load carrying capacity of the beam. The beam height is 80 cm. 85 cm is also available as an option on ploughs with shear bolt overload protection.

### The key advantages:

- ✔ Extremely rigid beam thanks to the over-dimensioned box section
- ✔ Comfortable and gentle turnover
- ✔ Safe and comfortable transport travel
- ✔ Constant working depth of all bodies thanks to the over-dimensioned beam
- ✔ High flexibility in the number of furrows
- ✔ Beam height 80 cm (85 cm as an option with shear bolt overload protection)

## High flexibility

The simple yet strong design of the Tyrok enables the use of an extendable beam system. This means that an additional furrow can be removed or added in next to no time.

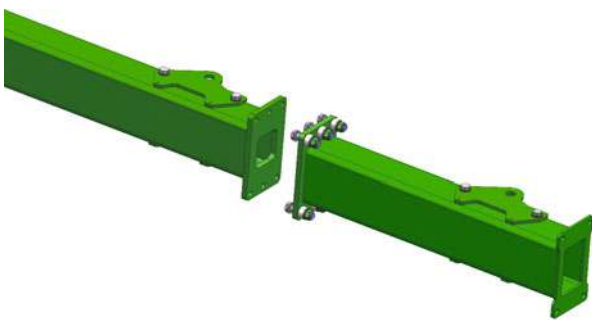

Extendable beam system with flange

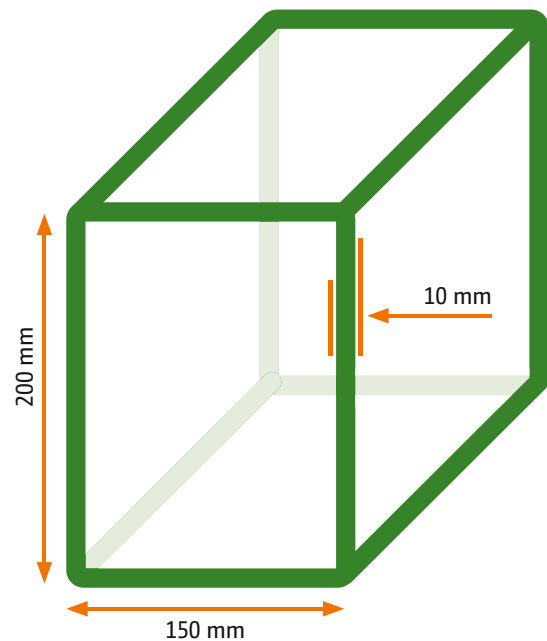

Section of the rigid beam

# Front furrow width

Always the right setting



## AutoAdapt – automatic adjustment of the front furrow when changing the furrow width

The front furrow width is automatically adjusted when changing the furrow width to enable a perfect matching up even under changing conditions. The standard hydraulic adjustment of the front furrow guarantees high quality operation under all conditions. You can also react quickly and easily to changing conditions since the front furrow can also be adjusted on the move. The swing arm is controlled directly by the cylinder during the process. As a result, inside wheel track dimensions from 1.2 m to 1.6 m are possible.

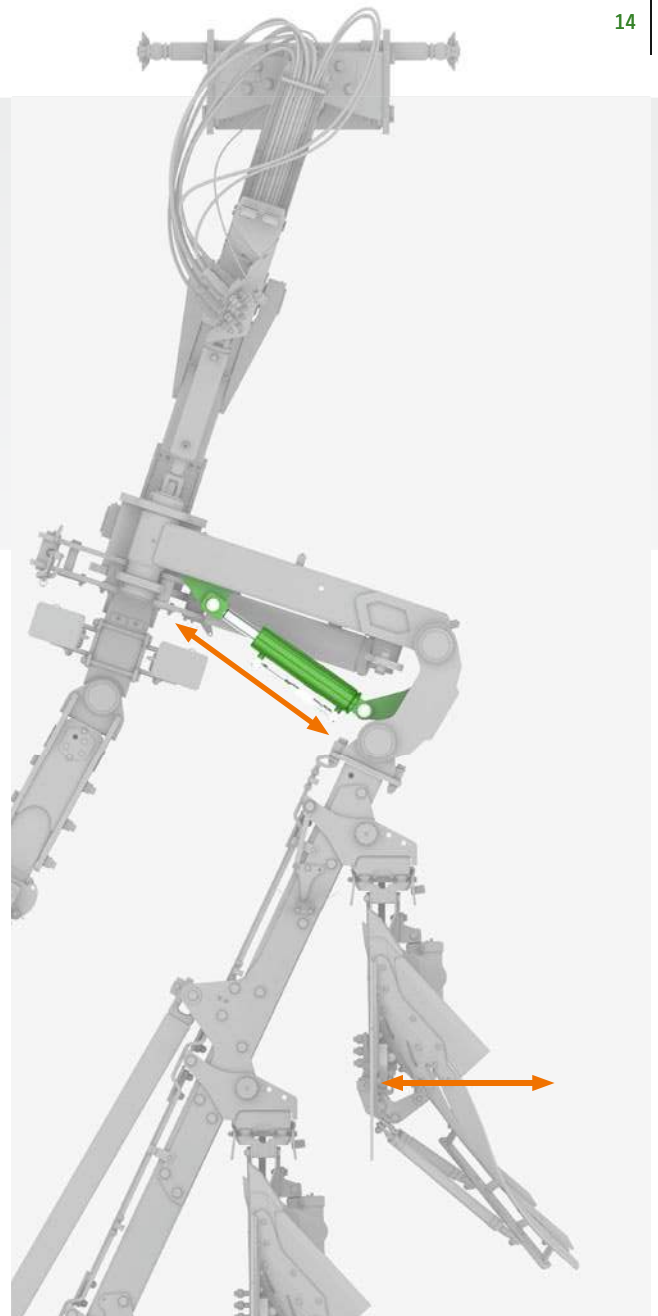

Intelligent kinematic system for adjustment of the front furrow width

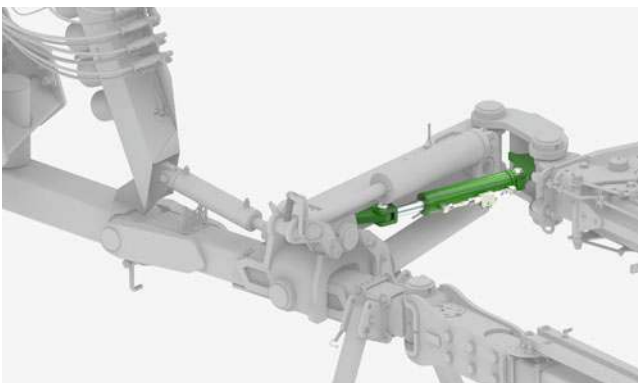

Hydraulic cylinder for adjusting the front furrow width

### The advantages thanks to AutoAdapt:

- ✔ Simple and comfortable adaptation of the front furrow to the furrow width
- ✔ Precise connection
- ✔ Robust, low-wear system for basic adjustment
- ✔ Highly responsive, even on the move, owing to the direct control of the first body
- ✔ Perfect plough profile even on variable soils, slopes or when changing tractors

# SpeedBlade plough bodies

Plough bodies from a new perspective



# SpeedBlade

Maximum speed – Minimum wear

## SpeedBlade – the new innovative plough bodies

The new SpeedBlade plough bodies, with their patented extra-large front shin on the mouldboard and the ©plus hardening process, ensure significantly less wear at high forward speeds. As ploughing speeds increase, the wear point shifts further backwards. Wear on conventional plough bodies begins directly on the mouldboard at higher speeds as a result of the small front shin of the mouldboard. Only the front shin of the mouldboard has to be replaced thanks to this patented enlarged front shin. This avoids the long-winded and expensive replacement of the entire mouldboard.



SpeedBlade plough body with the patented large mouldboard front shin and the ©plus hardening process

## SpeedBlade body with patented AMAZONE mouldboard front shin

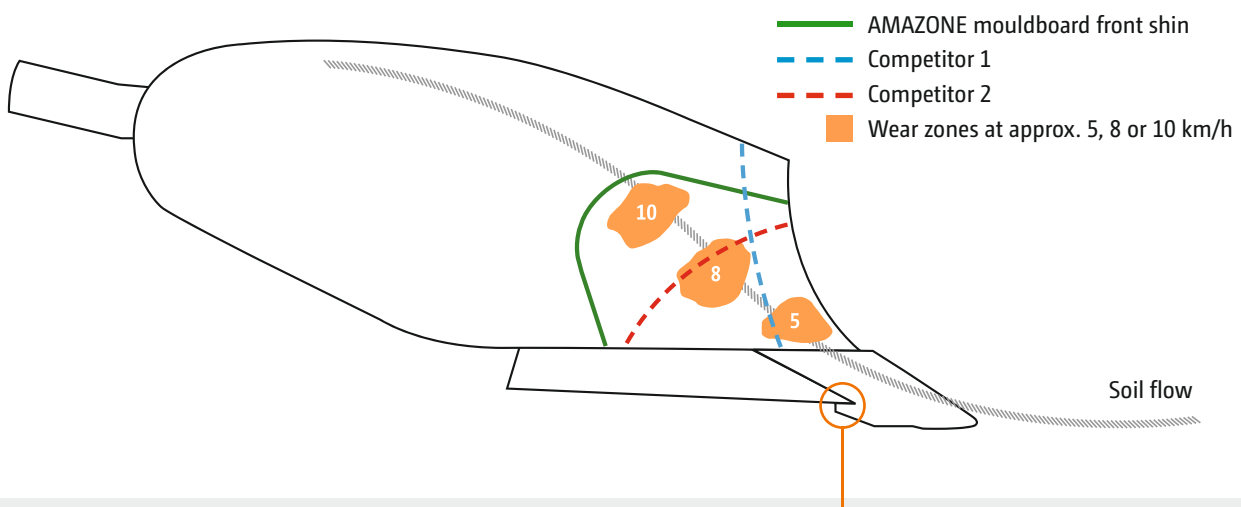

SpeedBlade body U 40

### The point covers the wing:

- ✔ The joint is therefore protected by the point
- ✔ Plant residues, baler twine, wire and root residues cannot get entangled

✔ The ©plus hardening process

# First-class quality for long-lasting wear parts

## The ©plus hardening process – the know-how of heat treatment

As a manufacturer of wearing parts for the soil tillage industry, we can look back on a history spanning decades. Continual advances in materials and production technology as well as our expertise in heat treatment are the basis for achieving the highest possible quality in our wearing parts for ploughs.

Carbon in its purest form, diamond, is the hardest naturally occurring substance. A hardening process which involves introducing carbon into the steel is used to increase the hardness and durability of ©plus wearing parts.

AMAZONE uses a unique hardening process to achieve a very high level of hardness on the front of components, such as the shin, to produce the optimum resistance to wear. The back remains relatively soft but at the same time extremely tough and impact resistant.

### Benefits of the ©plus hardening process:

- ✔ Longer service life
- ✔ High impact resistance
- ✔ Less pulling power requirement
- ✔ Reduced fuel consumption
- ✔ Less sticking to the smoother outer surface

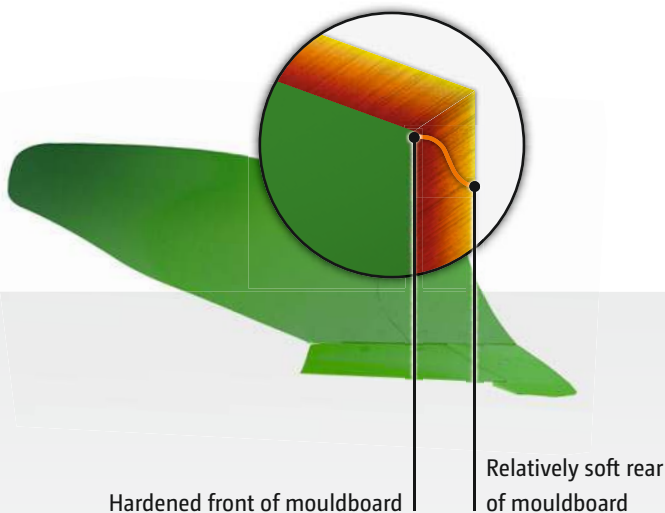

## Box section beam made of high-grade steel for a long service life

All the beams on AMAZONE ploughs are produced from a special high-tensile steel. The over-sized wall thickness means that, not only is the whole beam robust, but also all the bolt fixings are extremely strong with this heavy wall thickness also preventing any hole elongation or deformation of the box section around the bolt fixings. A further feature of the ploughs is the design of the plough beam without any weld seams.



## Cross-section of mouldboard – comparison of the different hardening methods

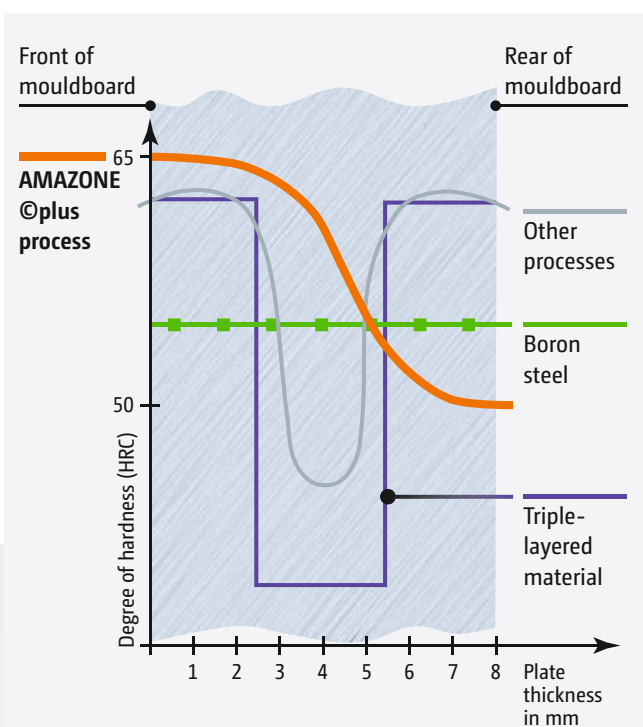

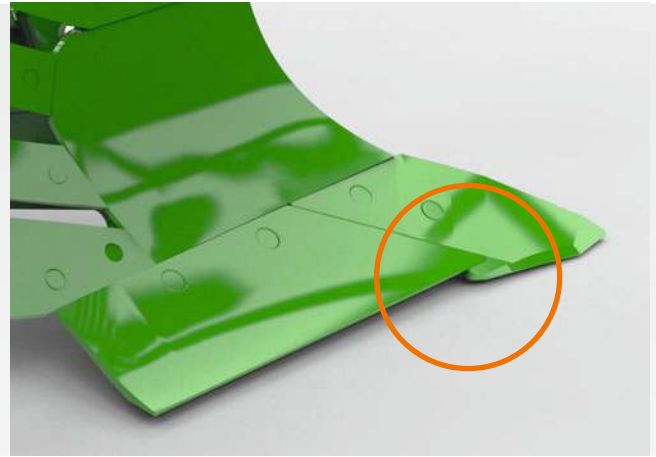

Coverage of the point with the wing

## Points – the right point for every application

The advantages of the different points:

### Integrated point:

- ✔ Angled forwards for good soil penetration
- ✔ The point covers the wing
- ✔ Reduced drag thanks to the smooth transition between the point and the front shin of the mouldboard

### Integrated HD point:

- ✔ Angled forwards for good soil penetration
- ✔ Hard-faced at the rear
- ✔ For an exceptionally long service life
- ✔ Reduced drag thanks to the smooth transition between the point and the front shin of the mouldboard

### Integrated S HD point:

- ✔ Narrower and angled even more forwards for excellent soil penetration
- ✔ Hard-faced at the rear
- ✔ For particularly tough conditions and a long service life
- ✔ Reduced drag thanks to the smooth transition between the point and the front shin of the mouldboard



Integrated HD point



Integrated point



Integrated S HD point

## Covered point – maximum ease of pull of the plough body

Since the point covers the wing, the joint is well protected by the point. This clever join up means that no plant residues, baler twine or root remnants get caught in the share.

## Open frog – to make things lighter

The shape of the open frog prevents soil from getting caught underneath. This means that the plough is even easier to pull. At the same time, the solid adjustable support of the slatted mouldboards provides more stability.



# AMAZONE plough bodies

Reliable and low-drag





Plough bodies	U 40	STU 40	STW 35	W 35	WXL 35	S 35
Minimum working depth approx. (cm)	18	18	18	15	15	15
Maximum working depth approx. (cm)	35	35	30	30	28	30
Maximum furrow width approx. (cm)	55	55	50	50	55	50
Suitability	- ○ + ++	- ○ + ++	- ○ + ++	- ○ + ++	- ○ + ++	- ○ + ++
Light, sticky soils (peat)						
Light soils (sand)						
Medium soils						
Heavy soils						
Very heavy soils (clay)						
Sloping terrain	○	○	○	○	○	○
Crumbling		●	●	●	○	○
Furrow clearance	○	●	●	●	●	○
Pulling power requirement	○	○	●	●	●	●
Soil inversion	○	○	●	○	●	●

Suitability:   
++ very well suited ○ suited   
+ well suited - poorly suited

# Overload protection

Always on the safe side



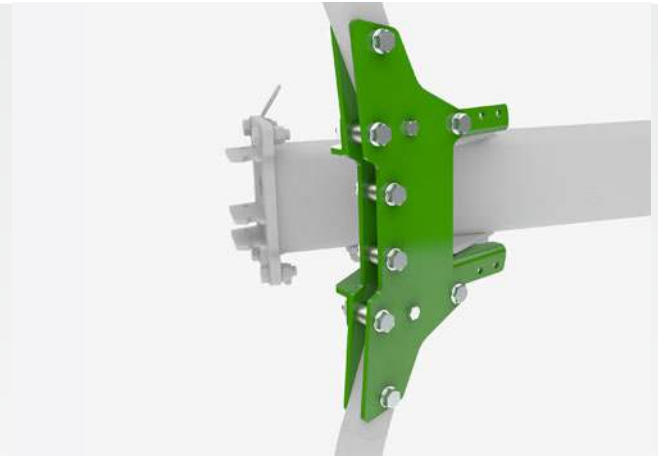
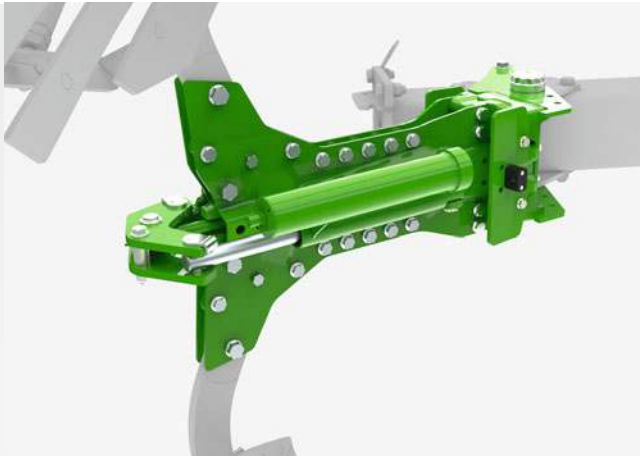

### Hydraulic overload protection

The hydraulic overload protection is basically a hydraulic cylinder with a directly connected, nitrogen-filled hydraulic accumulator on each pair of plough bodies. When triggered, the plough body pushes a piston into the accumulator via the hydraulic cylinder. The gas is compressed and automatically returns the body to its initial position after passing the obstacle. A choice can be made between the standard hydraulic protection with decentralised adjustment or the optional protection with central adjustment for convenient and quick adjustment of the release pressure of all bodies.

#### The benefits

- ✔ Simple adaptation of the release force
- ✔ Smooth and material-protecting operation
- ✔ Exchangeable ball joints and sockets
- ✔ As standard, with additional shear bolt

### Mechanical overload protection with shear bolt

Shear bolts are the tried and tested standard solution for this system. Under load, the shear bolt snaps off at the predetermined breaking point and the plough body gives way to the obstacle by swivelling upwards. The high release forces of the shear bolt enable use even in heavy and hard soils.

#### The benefits

- ✔ 6,200 kg shear force
- ✔ Clean shear-off owing to the double-cut, hardened flange plates

### It's better to bend than to break

The pressure acting on the plough bodies is determined by many different factors. The correct release pressure is of great importance so as to ensure that the body sits firmly in the ground, but no stones are ploughed up. This can be comfortably set with the hydraulic overload protection.

Unlike some other manufacturers, the release pressure decreases as the lift height increases. A gentle return of the body into the ground without damage can thus be ensured.

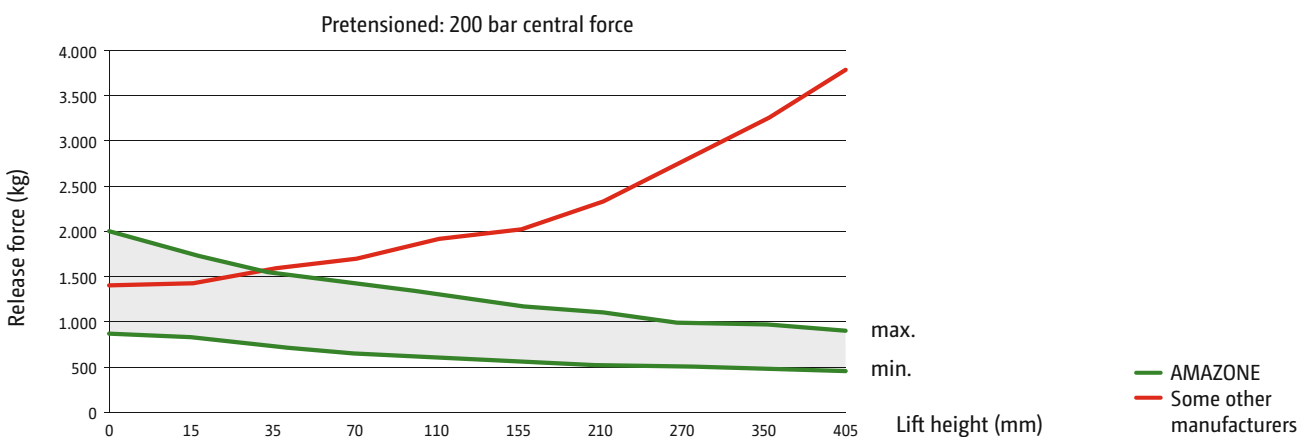

# Furrow width adjustment

Precise and comfortable



❗ "With two spindles for the tilt, clips for the cylinder for depth restriction on the support wheel and hydraulic front furrow and furrow width adjustment, including the durable and easy-to-read scales, mean that everything is virtually perfect."

(profi Practice test. "Really good work..." · 05/2023)

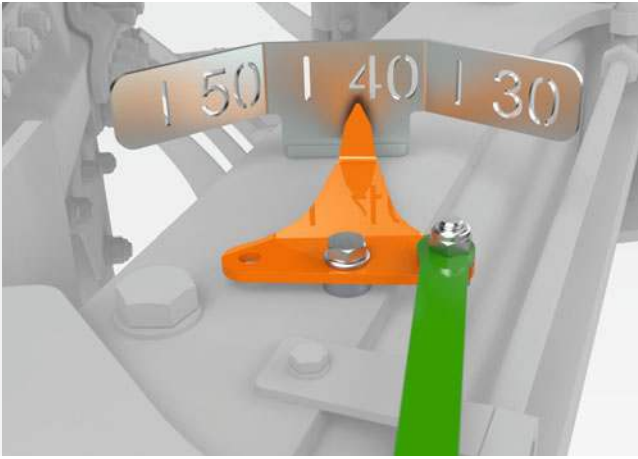

Hydraulic adjustment of the furrow width



Mechanical adjustment of the furrow width

## Tyrok V – comfortable hydraulic operation

The furrow width can be smoothly and hydraulically adjusted from the tractor on the Tyrok V. A very clearly visible display, consisting of a scale and indicator, keeps the driver informed of the furrow width setting. The integrated kinematics of the Tyrok V also automatically sets the pull point, the furrow width of the first body plus the angle of all the soil engaging tools and the support wheel.

### The advantages of the Tyrok V

- ✔ Variable furrow width from 33 cm to 55 cm per body
- ✔ Automatic adjustment of the front furrow when changing the working width thanks to AutoAdapt
- ✔ No readjustment necessary
- ✔ Comfortable and time-saving operation

## Tyrok – mechanically simple

The standard furrow width adjustment can be altered in 4 steps by manually pivoting the leg fixing consoles. The implement can therefore easily be adapted to different conditions (soil conditions, tractor, etc.). When the furrow width is adjusted, all the soil-engaging metal and support wheels are also automatically adjusted. No additional correction is necessary.



# The support wheel

Exact depth control combined with perfect boundary ploughing

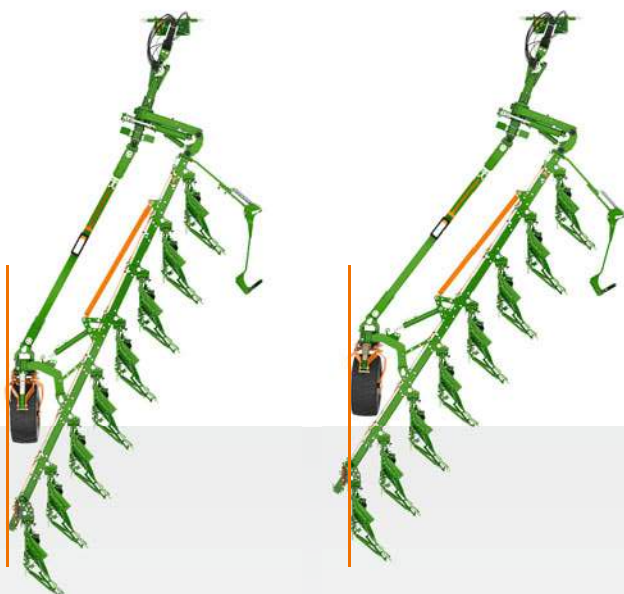

Furrow width per body: 42.5 cm

Furrow width per body: 55 cm

## Perfect boundary ploughing

The support wheel is positioned to the side of the beam so that ploughing close up to the field border is possible. The wheel is located inside the furrow width at maximum furrow width. The wheel is located inside the machine even at medium furrow width. Working directly near boundaries or obstructions becomes even more precise as a result.

-  "With a transport width of 2 m, and since the support wheel is damped via a nitrogen accumulator when the plough is lifted up slightly, you feel fine when driving on public roads."

(profi Practice test. "Really good work..." · 05/2023)



**Tyre size:**  
400/55-22.5



**Tyre size:**  
500/45-22.5



**Tyre size:**  
500/60-22.5

✔ The various tyre sizes mean that the support wheel can be optimally adapted to the practical requirements.



## Exact depth control

A choice of large-dimensioned support wheels provide optimum ground drive and exact depth control, even under the most arduous of conditions. The depth is easily adjusted by means of the support wheel, hydraulically from the cab, or manually using clips on the piston rod, without the need for tools. The scraper reliably cleans the wheel. The standard hydro-pneumatic suspension of the support wheel provides maximum safety and the highest comfort on the road.

### The benefits

- ✔ Safe and comfortable transport travel
- ✔ Reliable depth control



Depth adjustment of the support wheel

# Equipment for every application

Versatile for special requirements



## Trash boards

A cost-effective alternative to skimmers when incorporating surface crop residues. With additional support on the leg as standard.

## Sword landsides

The sword landside is an alternative to the disc coulters, which, especially on heavy, stony ground ensures a clean furrow wall and also reduces the wear and tear on the plough body.

## Landside protection

The landside protection increases the area of support of the plough on the furrow wall. This improves plough guidance significantly, especially on slopes. In order to enable the use of wider tyres in the furrow, a furrow-widening plate can be installed as an option on the last plough body.

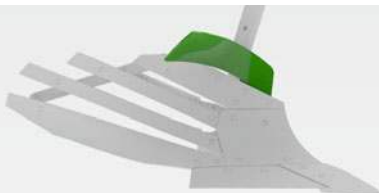

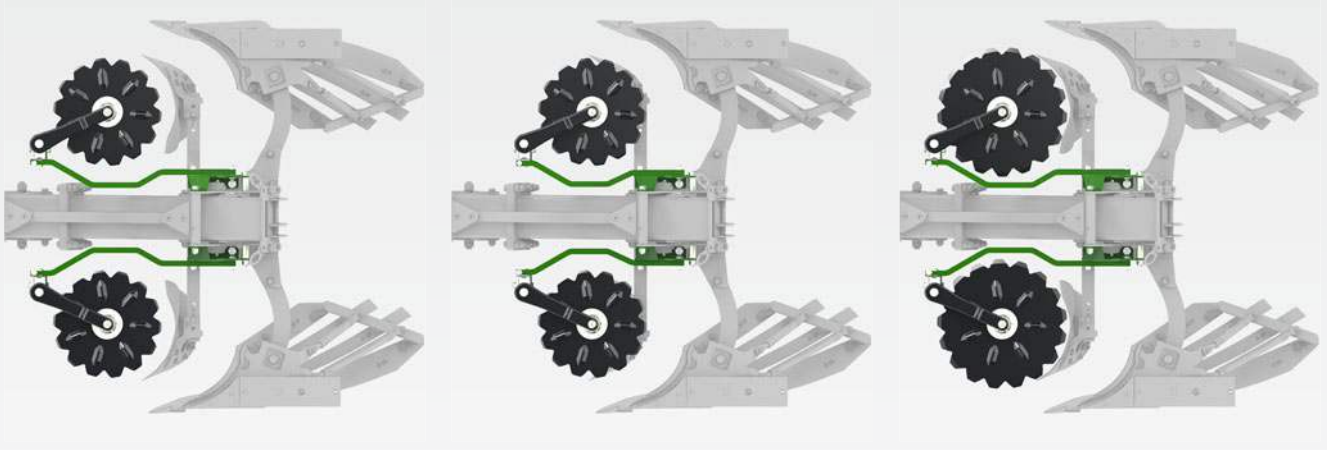

Serrated disc coulters, Ø 500 mm,  
with extended holder

Serrated disc coulters, Ø 500 mm,  
with short holder

Serrated disc coulters, Ø 600 mm,  
with extended holder

## Disc coulters – a clean solution

The disc coulters are important for a clean ploughing finish. Disc coulters also make a considerable contribution to efficient ploughing. The disc coulters' precise cutting action helps achieve full inversion and complete incorporation of any crop residues as well as leaving an effective furrow clearance.

The disc coulters are available in a smooth or serrated profile with a diameter of 500 mm and in a serrated profile of 600 mm.

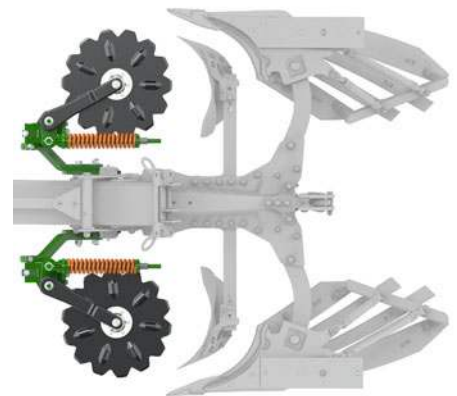

Spring-loaded, serrated disc coulters, Ø 500 mm

## Skimmers – for every situation

### M2 Skimmer

The M2 skimmer is universally suited for use in grassland ploughing as well as where there are large amounts of crop residues, especially maize straw.

### L2 Skimmer

The L2 Skimmer has an even stronger turned shape than the M2 Skimmer. It is therefore suitable for the incorporation of extreme volumes of organic harvest residues.

### G2 Skimmer

The use of the G2 skimmer ensures blockage-free ploughing, especially on heavy and sticky ground or when ploughing grassland for the first time. The easy adjustability of the skimmers means that the finish is left even more precise.



M2 Skimmer

L2 Skimmer

G2 Skimmer

## Subsoil points

Under certain conditions, it may be necessary to loosen the surface below the working depth of the plough body. The loosening legs are height-adjustable and can be easily replaced.



# Packers

Levelling and reconsolidation in one pass



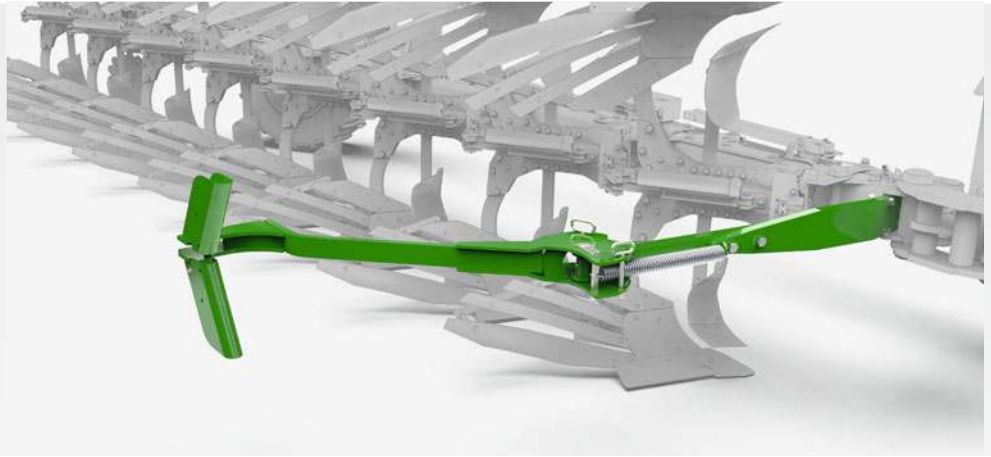

Robust and adjustable swivel press arm

## Swivel press arm

A swivel press arm can be installed as an option for combining the plough with a packer. All packer arms are equipped with a spring-loaded catcher which dampens the load peaks caused when picking up the packer.

The arm is operated hydraulically via an additional spool valve for optimum comfort.

## Packers – for even greater efficiency

AMAZONE has expanded its packer range via a strategic cooperation with the company Tigges for even greater efficiency on your farm. As a result, it is now possible to combine the Tyrok with packers from Tigges in an AMAZONE design. Various ring diameters as well as different ring profiles are offered. In addition, there is a choice of single or double ring packers up to a working width of 4.65 m.



# Tyrok on-land semi-mounted reversible plough

Maximum flexibility in the furrow or on-land



## Why plough on-land?

Tractors using wider tyres, as well as crawler tractors, can be used for on-land ploughing. This reduces the ground pressure in the deep ground layers and prevents plough pans. In addition, GPS steering systems can be used when on-land ploughing. This provides greater comfort for drivers and also ensures a precise match-up to the next furrow.

## High levels of comfort when changing between on-land and in-furrow modes

If the optimum on-land ploughing conditions are not present, because of the soil surface being too wet, you can quickly change over to in-furrow mode. The levers on the turnover arm for the changeover are very easy to reach and need only to be actuated once between modes. The swing-arms don't then need to be fixed or pinned and the front support wheels also no longer need to be set.

### Advantages of the front guide wheels

- ✔ Reliable depth control on unmoved or solid ground
- ✔ Manual setting only required when changing the working depth
- ✔ High self-driving effect



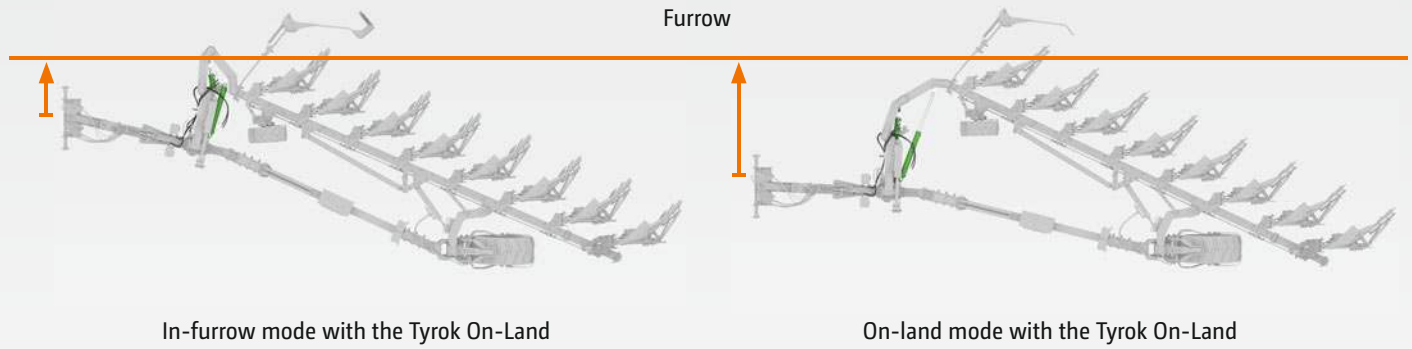

In-furrow mode with the Tyrok On-Land

On-land mode with the Tyrok On-Land



### SmartTurn – a more comfortable, quicker and yet extremely stress-free turnover

Thanks to its two-stage end-position damping, the plough's turnover process is slowed down shortly before reaching the end of its travel. This results in a damping effect which reduces stress on the plough structure when the cylinder is retracted. There is no need to make any compromises here as the stress-free turnover process is completed within a very short period.

An additional highlight is the automatic centre of gravity reduction when turning the Tyrok On-Land over. The low centre of gravity when turning increases the stability and provides better weight distribution on the lower links.

- ① Extending the cylinder
- ② The swing-arm is pushed forward
- ③ This results in the centre of gravity of the plough moving downwards

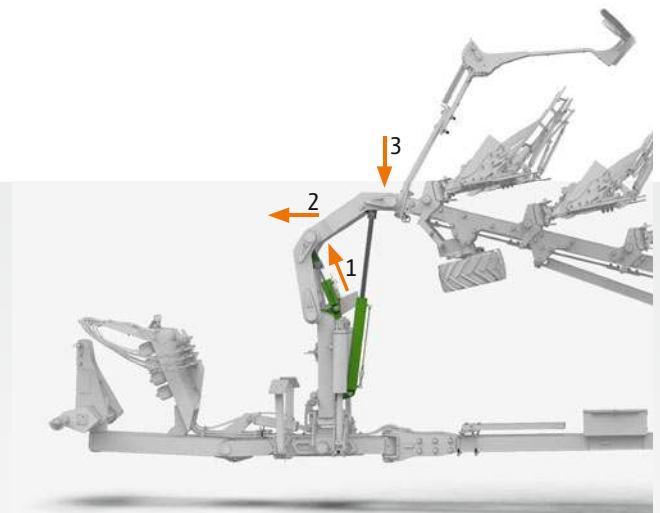

# AMAZONE – always in your vicinity

Your satisfaction is our challenge



## Original AMAZONE Parts

Verschleißteilkatalog  
für Landtechnik und Kommunaltechnik

Catalogue pièces d'usure  
pour machines agricoles et gamme espaces verts

Wearing parts catalogue  
for agricultural machinery and groundcare products

Каталог изнашиваемых деталей  
для сельскохозяйственной и коммунальной техники

PDF-DOWNLOAD  
[www.amazone.net/parts](http://www.amazone.net/parts)



### AMAZONE SmartService 4.0

Due to the increasing use of ever more complex machine technology, AMAZONE utilises, with the SmartService 4.0, both virtual and augmented reality as well as digital media for service, training and maintenance advice.

- 1 **SmartTraining:** Training and instruction in the use of complex machinery by using Virtual Reality Technology (VR).
- 2 **SmartLearning:** Interactive driver training for the user for complex machinery operation ([www.amazone.net](http://www.amazone.net)).
- 3 **SmartInstruction:** Repair or maintenance instructions using Augmented Reality (AR) and mobile terminal equipment.
- 4 **SmartSupport:** Direct local support from the service technician via Augmented Reality (AR) and mobile devices.



### The satisfaction of our customers is the most important objective

We rely on our expert sales partners for this. Also for service queries they are the reliable contact partner for end users and contractors. Due to continuous training, our sales partners and service technicians are always up to date when it comes to looking after our state-of-the-art technology.

### Better to choose the original right from the start

Your machines are subjected to extreme use! The quality of AMAZONE spare parts and wearing metal offers you the reliability and security you need for efficient soil tillage, precise sowing, professional fertilisation and successful crop protection.

Only original spare parts and wearing metal parts provide the durability and functionality expected from AMAZONE machinery. This guarantees an optimum quality of work. Original parts at fair prices pay for themselves in the end.

### We provide you with a first-class parts service

The parts centre in Tecklenburg-Leeden is the base for our worldwide parts logistics system. This ensures optimum availability of spare parts, even for older machines.

Orders for parts in stock at the Tecklenburg-Leeden parts centre which, if placed by 5 p.m., leave our premises the same day. 42,000 different spare parts and wearing metal parts are handled and stored via our modern warehousing system. Up to 1,000 orders are sent out to customers every day.

### So opt for the original!

#### The advantages of original spare parts and wearing metal parts

- ✔ Quality and reliability
- ✔ Innovation and efficiency
- ✔ Immediate availability
- ✔ Higher resale value of the used machine



## Tyrok semi-mounted reversible ploughs

Model	Tyrok 400 (OL)				Tyrok 400 (OL) S			Tyrok 400 (OL) V			Tyrok 400 (OL) VS		
	6	7	8	9	6	7	8	6	7	8	6	7	8
No. of furrows	6	7	8	9	6	7	8	6	7	8	6	7	8
Tractor power up to (kW/hp)	295/400												
Interbody clearance (cm)	100												
Frame height (cm)	80, 85				80			80, 85			80		
Furrow width adjustment	Manual				Manual			Hydraulic			Hydraulic		
Overload protection	Shear bolt				Hydraulic overload protection			Shear bolt			Hydraulic overload protection		
Furrow width per body (cm)	35, 40, 45, 50				35, 40, 45, 50			33 – 55			33 – 55		
Support wheel (dimension)					400/55-22.5			500/45-22.5			500/60-22.5		
Weight of the base machine, from (kg)	3,540	3,788	4,129	4,279	4,160	4,497	4,853	3,630	3,899	4,140	4,245	4,602	4,860



Illustrations, content and technical data are not binding and may differ depending on the level of equipment. Country-specific road traffic regulations apply and must be complied with, meaning that special approval may be required. The permissible axle loads and total weights of the tractor should be checked. Not all the listed combination options are possible with all tractor manufacturers.



**AMAZONEN-WERKE H. DREYER SE & Co. KG**  
P. O. Box 51 · 49202 Hasbergen-Gaste/Germany  
Phone +49 (0)5405 501-0 · Fax +49 (0)5405 501-193